

USERS' MANUAL AND INSTALLATION GUIDE



Nature System®



A.F.C. System®

Basic System

SUMMARY

1	GENERAL	5
1.1	IDENTIFICATION OF THE MACHINE	5
1.2	MARKING OF THE MACHINE	6
1.2.1	<i>Opening the door</i>	6
2	PACKAGING AND TRANSPORT	7
2.1	PACKAGING	7
2.2	TRANSPORT	7
3	INSTALLATION OF THE MACHINE	8
3.1	VENTILATING THE PREMISES	9
3.2	FILTER UNIT	9
3.3	METAL PRE-FILTER	9
3.4	ELECTROSTATIC CELL	10
3.4.1	<i>ionisation wires</i>	11
3.4.2	<i>collection blades</i>	11
3.4.3	<i>insulators</i>	11
3.4.4	<i>contact terminal strip</i>	11
4	SAFETY DEVICES	11
4.1	MECHANICAL SAFETY DEVICES	11
4.2	ELECTRICAL SAFETY DEVICES	12
4.2.1	<i>Electronic circuit protection devices</i>	12
4.3	FUSE	12
5	ORDINARY MAINTENANCE	13
5.1	FILTER MAINTENANCE	13
5.1.1	<i>Access Door</i>	13
5.1.2	<i>Washing the filters</i>	14
5.2	GENERAL INSPECTION OF THE FILTERS	15
5.3	CLEANING THE MACHINE	15
6	AVAILABLE VERSIONS	16
7	NATURE SYSTEM[®]	18
7.1	CONTROL PANEL	19
7.1.1	<i>DISPLAY</i>	19
7.1.2	<i>RECEIVER</i>	19
7.1.3	<i>MANUAL, TEST, ON-OFF FILTER AND RESET BUTTONS</i>	20
7.1.4	<i>OPERATION OF THE MACHINE</i>	20
7.1.5	<i>FILTERING STATUS</i>	21
7.2	INFRARED REMOTE CONTROL UNIT	21
7.3	POWER SUPPLY AND ANTI BLACK-OUT SYSTEM	21
7.4	ENVIRONMENTAL REVITALISATION (RIVITALIZZAZIONE AMBIENTALE [®])	22
7.5	PURIFICATION	22
7.6	NORMAL CONDITIONS OF OPERATION	22
7.7	NIGHT-TIME REVITALISATION WITH ENVIRONMENTAL DEODORIZATION	23
7.8	SIGNALS	23
7.9	STATE OF FILTRATION EFFICIENCY	23
7.10	OPTIMAL APPLICATION OF THE REVITALIZER	24
7.11	ELECTRONIC CIRCUIT ALARM SIGNALS	25
7.12	ELECTRONIC CIRCUIT ANOMALOUS SIGNALS	26
8	AFC SYSTEM[®]	27
8.1	CONTROL PANEL	28
8.1.1	<i>DISPLAY</i>	28
8.1.2	<i>(RECEIVER)</i>	28

8.1.3	MANUAL, TEST, ON-OFF FILTER AND RESET BUTTONS.....	29
8.2	OPERATION OF THE MACHINE.....	29
8.3	FILTERING STATUS	30
8.4	INFRARED REMOTE CONTROL UNIT	30
8.5	POWER SUPPLY AND ANTI BLACK-OUT SYSTEM	30
8.6	PURIFICATION	31
8.7	SIGNALS.....	31
8.8	STATE OF FILTRATION EFFICIENCY.....	31
8.9	ELECTRONIC CIRCUIT ALARM SIGNALS	32
8.10	ELECTRONIC CIRCUIT ANOMALOUS SIGNALS	33
9	BASIC SYSTEM.....	34
9.1	CONTROL PANEL	35
9.2	VISUALISATION OF SPEED	35
9.2.1	RECEIVER.....	35
9.2.2	MANUAL AND ON-OFF FILTER BUTTONS.....	36
9.3	OPERATION OF THE MACHINE.....	36
9.4	INFRARED REMOTE CONTROL UNIT	36
9.5	POWER SUPPLY AND ANTI BLACK-OUT SYSTEM	36
9.6	PURIFICATION	37
9.7	SIGNALS.....	37
9.8	STATUS OF FILTRATION EFFICIENCY	37
9.9	ELECTRONIC CIRCUIT ALARM SIGNALS	37
10	TECHNICAL DATA	38
11	CERTIFICATIONS.....	38
11.1	CERTIFICATION C.N.R.	38
11.2	CERTIFICATION OF COMPONENTS	38

1 GENERAL

Air cleaners and Revitalizers 50P, built for the purposes of improving the characteristics of the air in closed environments.

There are available two different technologies: Nature System, Basic System.

1.1 IDENTIFICATION OF THE MACHINE



There is a plate in every machine showing the model and the series number which identify the machine.
This plate is located on the inside of the machine and it is therefore necessary to open the door of the machine itself to see it.

identification plate

The plate shows the technical data of operation and the sign of identification of the machine.
When you call for technical assistance, provide the data relative to the model of the machine, its type and series number.

MODEL		
TYPE		
SERIAL NUMBER		
KW POWER MAX		*****
Hz FREQUENCY RANGE		*****
AC VOLTAGE		*****
A CURRENT MAX		*****
FUSE		*****
<p>- PER UNA PROTEZIONE CONTINUA CONTRO I RISCHI D'INCENDIO USARE SOLO FUSIBILI DELLO STESSO TIPO E DELLA STESSA PORTATA</p> <p>- PER UNA PROTEZIONE CONTINUA CONTRO I RISCHI D'INCENDIO USARE SOLO FUSIBILI DELLO STESSO TIPO E DELLA STESSA PORTATA</p> <p>- PER UNA PROTEZIONE CONTINUA CONTRO I RISCHI D'INCENDIO USARE SOLO FUSIBILI DELLO STESSO TIPO E DELLA STESSA PORTATA</p> <p>- PER UNA PROTEZIONE CONTINUA CONTRO I RISCHI D'INCENDIO USARE SOLO FUSIBILI DELLO STESSO TIPO E DELLA STESSA PORTATA</p>		<p>- L'APPARECCHIATURA DEVE ESSERE COLLEGATA ALLA PRESA DI TERRA</p> <p>- L'APPARECCHIATURA DEVE ESSERE COLLEGATA ALLA PRESA DI TERRA</p> <p>- L'APPARECCHIATURA DEVE ESSERE COLLEGATA ALLA PRESA DI TERRA</p> <p>- L'APPARECCHIATURA DEVE ESSERE COLLEGATA ALLA PRESA DI TERRA</p>

Model

Type

N series number

1.2 MARKING OF THE MACHINE

The EC conformity mark is located on the control panel of the machine.

1.2.1 *Opening the door*

For opening the door it is necessary to introduce a finger in the proper slit and pull.

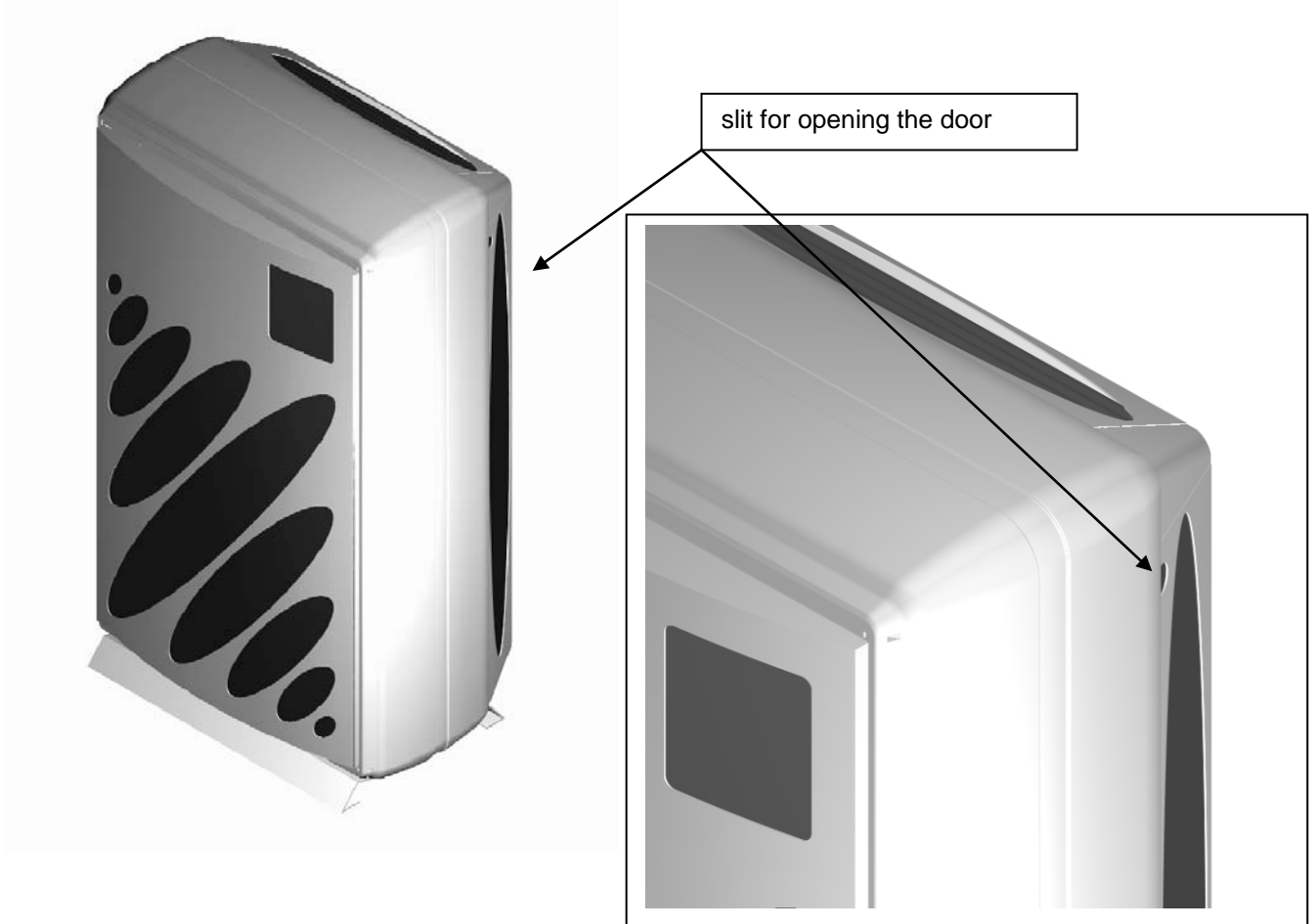

2

PACKAGING AND TRANSPORT

2.1 PACKAGING

The machine is supplied in a cardboard box internally lined with polystyrene.

We recommend keeping all the packaging just in case the machine has to be returned to the manufacturer or the dealer for extraordinary maintenance or repairs.

The following objects should be found in the box:

- the required machine
- users' manual and guarantee leaflet
- remote control unit
- plug

2.2 TRANSPORT

To limit damage and consequent charges for unforeseen repair work, if the machine has to be sent to the manufacturer for overhaul or repair, the following procedure is recommended:

- pack the machine in the original carton; if this is not possible, you must pack the machine with polystyrene protection.
- ship to the manufacturer or to the local dealer.

3

INSTALLATION OF THE MACHINE

For a correct function, place the machine so that the air can fulfil the cycle as figured on the picture. The air that comes out of the hinder air diffuser must not find near obstacles which can obstruct to close the cycle of purifying.

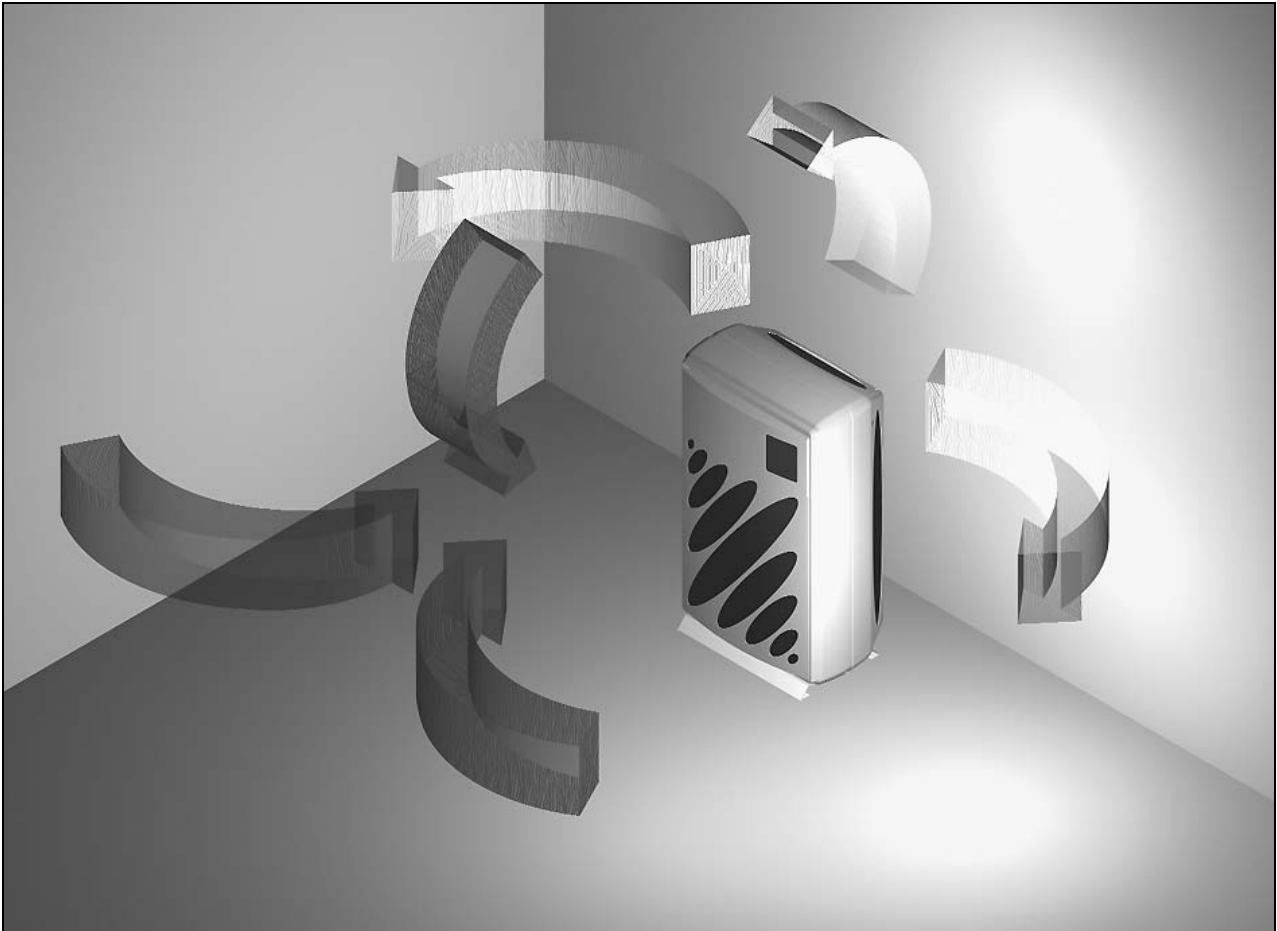

3.1 VENTILATING THE PREMISES

All rooms where people are present carrying out any activity must be fitted with appropriate apparatuses which guarantee adequate reoxygenation of the environment.

This reoxygenation is fundamental for the well-being of people and must be realised bearing in mind that every person needs at least 12.5m³ of air every hour where there is a high-efficiency air purification system. It is therefore necessary to provide the premises with an air introduction system in proportion to the average number of people present in them.

To calculate the quantity of air in m³/h to introduce from the exterior, it is sufficient to multiply the average number of persons present by a coefficient of 12.5.

3.2 FILTER UNIT

There are two different filters in the machine:

- metal pre-filter 50P
- electrostatic cell 50P

3.3 METAL PRE-FILTER

The metal pre-filter is for trapping the bigger particles present in the air and for distributing the flow uniformly. Depending on the model it is fitted in, it can have different dimensions which are illustrated below.

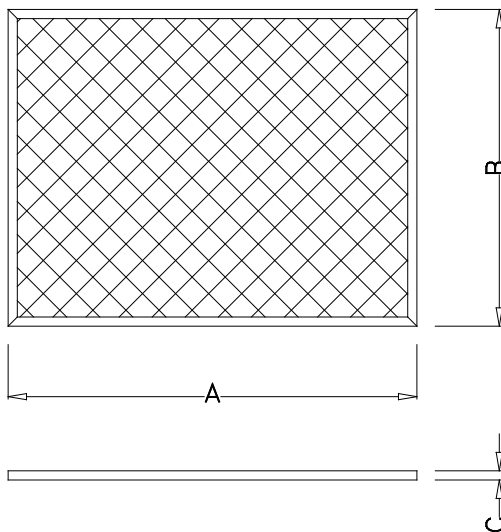

	DIMENSIONS		
FILTER MODEL	A	B	C
50p	344	310	6

During operation, the metal pre-filter must always be inserted in its seat.
During maintenance, it must be handled with care to prevent deformation or damage

3.4 ELECTROSTATIC CELL

The electrostatic cell filters the pollutant particles with an efficiency of 99%. Its dimensions vary depending on the model it is fitted in.

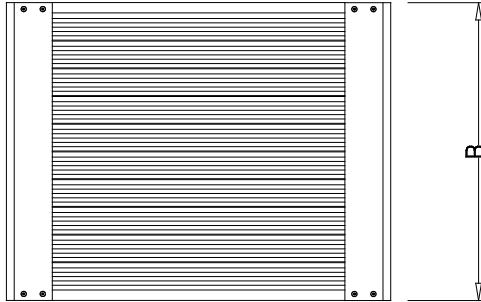

FILTER MODEL	DIMENSIONS		
	A	B	C
50p	344	310	115

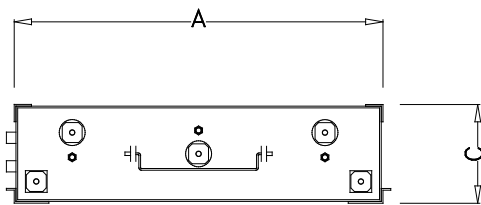

The cell is built entirely in anticorodal aluminium. There are four distinct zones in the cell:

- A - ionisation wires
- B - collection blades
- C - insulators
- D - contact terminal strip

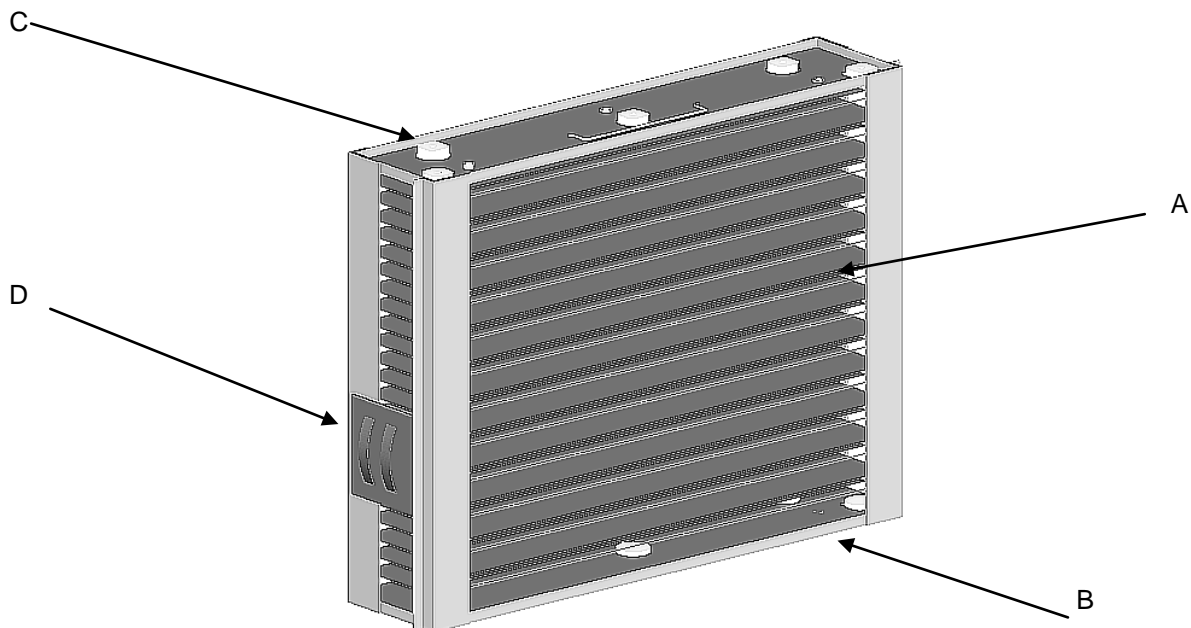

3.4.1 *ionisation wires*

The electrostatic cell has 9 ionising wires. These must be intact, clean and well-tensioned at all times. If one breaks, it is necessary to replace it. The technical service must be called in this case.

The manufacturer will not guarantee the efficiency of the filter unit if non-original wires are inserted or wires which are not of the type recommended by the technical service.

3.4.2 *collection blades*

The function of the collection blades which make up the central body of the cell is to capture and hold the pollutant agents. Visually, the blades must be straight, without undulations and free from trapped foreign bodies.

3.4.3 *insulators*

The insulators are built in an extremely high quality ceramic material and their function is to electrically insulate the high-voltage parts of the electrostatic cell from the earthed parts.

They must be dry and thoroughly clean after maintenance.

3.4.4 *contact terminal strip*

The terminal strip for the contacts is the point through which the electrical connection is made between the electronic circuit and the electrostatic cell. During maintenance, inspect to ensure that the flexible arches are intact. Also ensure that there are no burns or cracks on the terminal strip caused by the voltage.

4

S A F E T Y D E V I C E S

The machine is fitted with mechanical and electrical safety devices which must not be removed or altered for any reason.

4.1 MECHANICAL SAFETY DEVICES

The grill, where the air to be cleaned passes through, is designed to protect persons from accidental contact with the live parts. This grill can only be removed in the event of extraordinary maintenance or repair operations.

In all cases, before removing it, it is necessary to cut off the electrical power.

NEVER INSTALL OR START THE AIR PURIFIER WITHOUT THE PROTECTIVE GRILL.

There are air diffusion fins in the top of the machine. They have the double function of diffusing the purified air and avoiding accidental contact with the electric fan which, in turn, is protected inside by a further protective grill. These fins can only be removed in the event of extraordinary maintenance or repair operations. In all cases, before removing a safety device, it is necessary to cut off the electrical power.

NEVER INSTALL OR START THE MACHINE WITHOUT THE DIFFUSION FINS.

4.2 ELECTRICAL SAFETY DEVICES

The machine is provided with a door, through which access to the filters is permitted so as to carry out normal maintenance. This door is provided with a pin which actuates a safety switch, which cuts off the power supply if the door is opened without first cutting off the power by disconnecting the plug.

CUT OFF THE POWER SUPPLY BEFORE CARRYING OUT ANY OPERATION ON THE MACHINE.

The pin which actuates the microswitch must not be modified for any reason, and must not be blocked in the closed position in any way so as not to compromise safety. If the microswitch is broken the machine will stop. Contact the technical service for the replacement of this component.

4.2.1 *Electronic circuit protection devices*

The electronic circuit is provided with a series of protection devices which automatically cut off the high voltage whenever a machine malfunction occurs which could lead to its breakdown. There is a thermal fuse inside the machine (available only for the versions AFC System and NATURE System) which cuts off the power supply if a short circuit occurs in the electronic section down-line from the transformer.

There is a mains protection fuse in the power plug which cuts off the power to the machine in the event of short-circuiting of the transformer.

4.3 Fuse

Inside the machine is inserted a fuse, which you can find as follows:

- cut off the power supply of the machine
- open the door
- remove the cell and pre-filter
- open the fuse holder

Blown fuses must be replaced with others with the same characteristics and has to be done by the technical service.

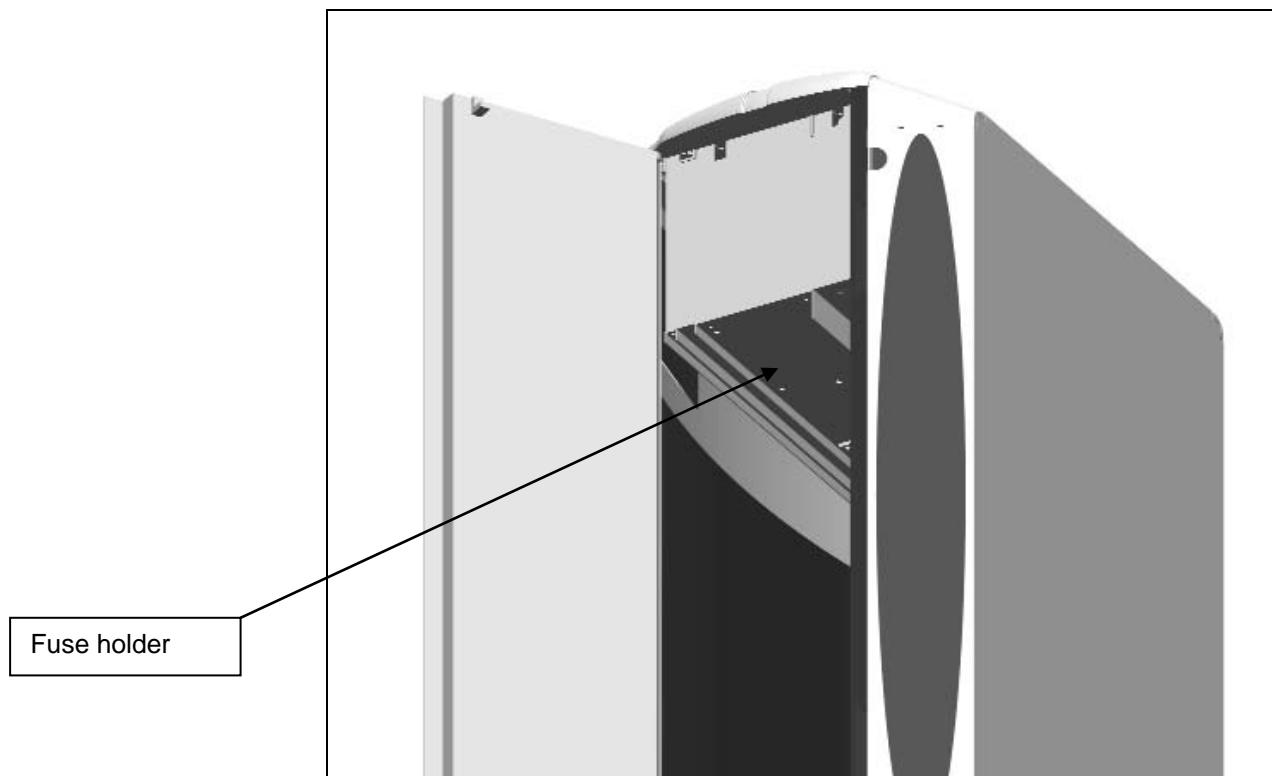

5

ORDINARY MAINTENANCE

Ordinary maintenance involves:

- maintenance of the filter unit
- general inspection of the machine

Extraordinary maintenance is carried out by specialised personnel.

5.1 FILTER MAINTENANCE

To carry out filter maintenance, it is necessary to gain access to them through the provided door and consists in washing the filter cell and the metal pre-filter

5.1.1 Access Door

For opening the machine, pull the door on the upper part.

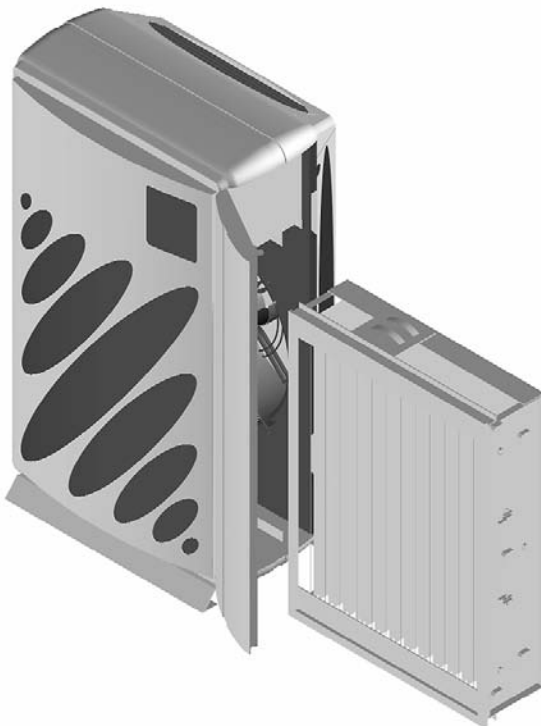

5.1.2 *Washing the filters*

Filter maintenance is important both for the correct operation of the machine and for constant performance with the passage of time. The following materials are required for maintenance:

- 1) Two plastic trays, one with the bottom raised 2-3 cm for decanting the dirt. As an alternative to the raised bottom, use a stainless steel frame.
- 2) Non-corrosive detergent for washing the electrostatic cells, supplied by an authorised dealer.
- 3) A rubber tube for rinsing the filters.
- 4) Vinegar.

Prepare the tray with the raised bottom with warm water (max 45°C). Dilute the detergent in the proportions indicated on the label of the detergent itself.

Put the vinegar and water in the other (1 litre of vinegar for every 20 litres of water).

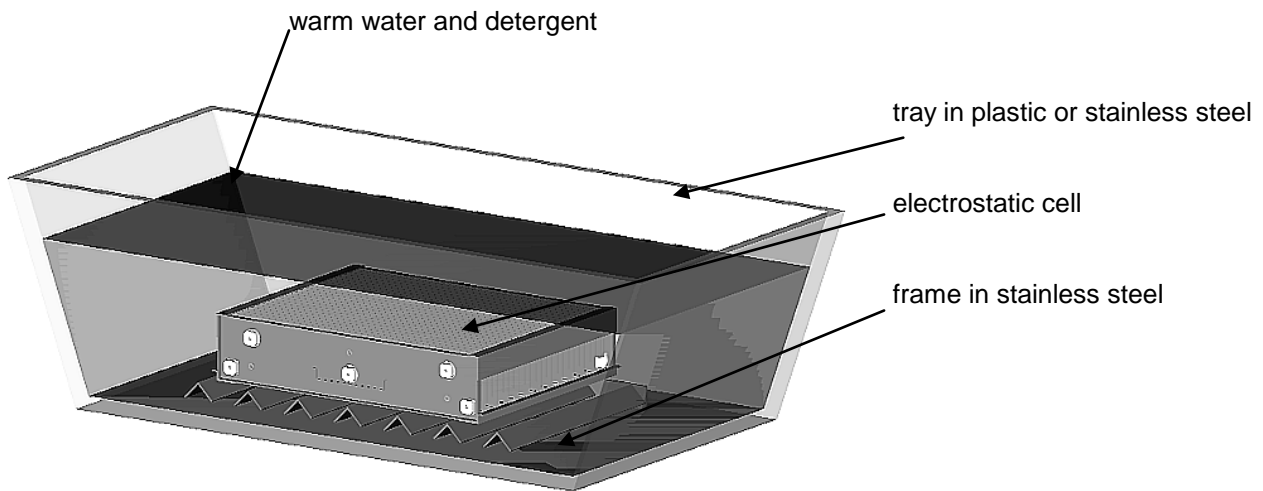

To wash, proceed as follows:

- a) immerse the electrostatic cell in the tray with the detergent and soak until the dirt is dissolved
- b) remove the electrostatic cell and rinse thoroughly with running water, taking care not to break the ionisation wires
- c) immerse the cell in the tray containing the water and vinegar and leave to soak for 5-10 minutes.

rinsing with current water

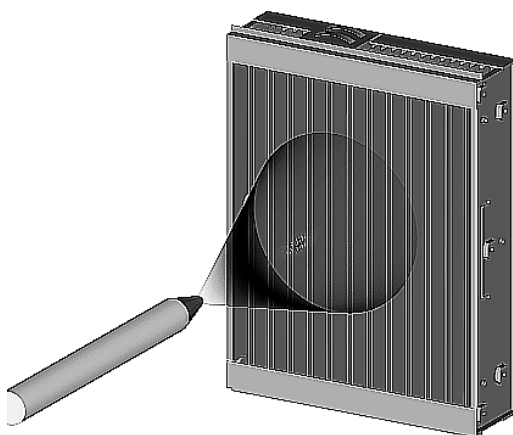

drying

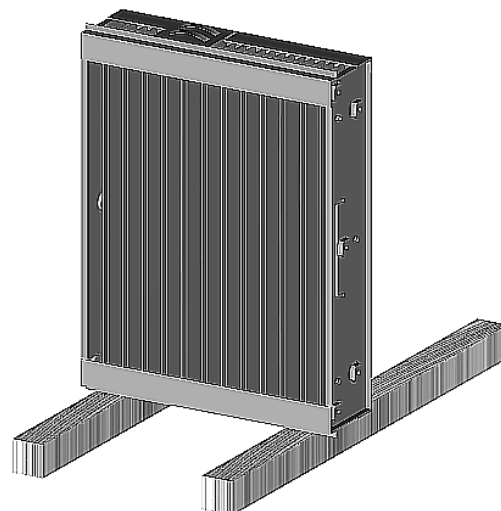

- d) remove the cell and leave it to dry in a warm place, keeping it raised from the ground by wooden strips (ovens with a maximum temperature of 60°C are tolerated).
- e) examine the state of the ionisation wires, stretching them slightly to check their mechanical strength. Use a cotton flock and methylated spirits to remove any residual traces of dirt.
- f) Ensure that the cell is thoroughly clean and dry before reinstalling it.

When maintaining the pre-filter, first remove the dust deposited in it using an ordinary vacuum cleaner. Then proceed with washing as follows:

- a) Immerse the pre-filter in the tray containing the detergent diluted in warm water and leave to soak for about half an hour.
- b) Remove the pre-filter from the tray and rinse thoroughly with water.
- c) Leave to dry in a warm ventilated environment.

5.2 GENERAL INSPECTION OF THE FILTERS

The state of the filters must be inspected every time they are washed so as to prevent air cleaner malfunction and problems.

INSPECTION	FAULT	OPERATION
ionisation wires	breakage of a wire	change the ionisation wire
ionisation wires	rough surface with material deposits	clean the wire with a cloth soaked in alcohol or replace
ceramic insulators	dirty with material deposits	wash the cell again
ceramic insulators	breakage or presence of cracks	replace the insulators
high voltage terminal strip	burning caused by high voltage	replace the high voltage terminal strip

The following inspections must be made on the filters:

- check that the internal mesh of the pre-filter is compact and that no wires protrude from the containing meshes.
- check that the frame is not deformed or damaged.

If the pre-filter is badly damaged, replace it with a new one.

5.3 CLEANING THE MACHINE

To clean the outside, use a cloth sprayed with methylated spirits.

Use a brush with soft bristles to clean the air outlet fins.

To clean the inlet grill, use a vacuum cleaner with a dusting attachment.

6

AVAILABLE VERSIONS

The 50P line is manufactured in three versions. For distinguishing which version you have, you should control the label placed outside on the machine or to check the control panel.



Nature System[®] is the Top version and identifies the Environmental Revitalizer. It is used a digital technology for the controlling of all functions. The operations carried out by this machine are reported in the following definitions.

NATURE SYSTEM[®]

Identifies the method used in confined environments to obtain an air quality as close as possible to a "natural" one.

ENVIRONMENTAL REVITALISATION (RIVITALIZZAZIONE AMBIENTALE[®])

Identifies the operation carried out by the apparatus to create ionic equilibrium, inside a confined environment, as close as possible to the ideal one for **well-being**.

ENVIRONMENTAL REVITALIZER (RIVITALIZZATORE AMBIENTALE[®])

Identifies the apparatus which, in an equilibrated manner, carries out various complex operations with the maximum security and reliability to render the environment comfortable, with characteristics similar to natural ones uncontaminated by the presence of man.

HIGH-EFFICIENCY FILTERING

Identifies the operation of purifying the confined environment. This operation is carried out with an efficiency which is constant with time and in a completely autonomous manner, thanks to the microprocessor which guarantees optimal performance whatever situations it is used in.

NIGHT-TIME DEODORIZATION

Identifies the work carried out by the Revitalizer during the night to eliminate the stagnant odour from the premises as well as typical residual odours in badly-aired environments.
The air is fresher and bracing the next day.

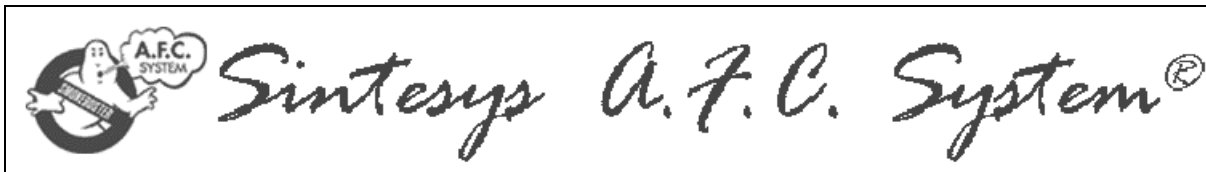

AFC SYSTEM[®] is the Top version of Environmental Air Purifiers and is using a digital technology for the controlling of its functions. The operations carried out by this machine are reported in the following definitions:

AFC SYSTEM[®]

Identifies the method used by the microprocessor of the machine to gesture in complete autonomously way the parameters of the filtration, depending from the chosen performance of function and the level of saturation of the electrostatic cell.

HIGH-EFFICIENCY FILTERING

Identifies the operation of purifying the confined environment. This operation is carried out with an efficiency which is constant with time and in a completely autonomous manner, thanks to the microprocessor which guarantees optimal performance whatever situations it is used in.

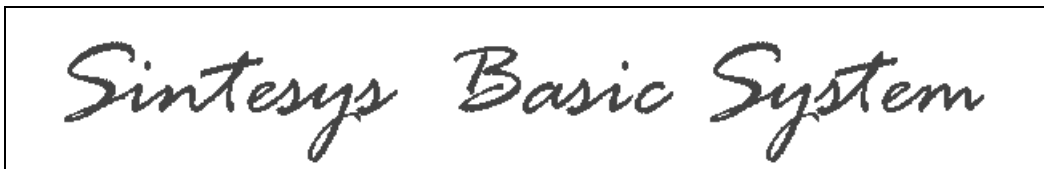

BASIC SYSTEM is a basic version and is using a traditional technology.

7

NATURE SYSTEM®

The NATURE SYSTEM® is composed of the following elements:

Electronic control of environmental revitalisation (rivitalizzazione ambientale®)

The System automatically carries out all the controls and gives the commands to the Environmental Revitalisation along with the information required on the operating status of the apparatus.

Infrared remote control unit

The remote control unit allows the user to control the operation of the Revitalizer from a distance of about 6÷7 metres; in particular, the air flow can be varied.

High-efficiency filtration unit

This element feeds the filtering System in a completely automatic manner, maintaining constant high efficiency in all situations.

Environmental Revitalisation Unit

This element feeds environmental revitalisation in an optimal manner to reach ionic equilibrium in completely different situations and environments.

7.1 CONTROL PANEL

All information regarding the operating status of the machine is displayed on the control panel.

The control panel allows the user to:

- select the air flow
- activate/deactivate environmental revitalisation
- turn off any alarms indicating apparatus malfunctions
- constantly control all the functions relating to operation (air flow, environmental revitalisation, filtration efficiency, alarm situation).

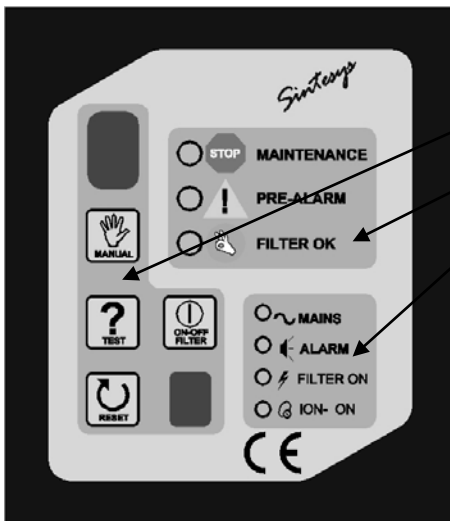

The control panel is divided in three zones:
 1 – COMMANDS AND VISUALISATION OF THE SPEED
 2 – FILTERING STATUS
 3 – OPERATION OF THE APPARATUS

The devices which permit manual operation and visual control of the operating conditions are given here below.

7.1.1 DISPLAY

When the machine works normally, the single-figure display shows the operating air flow (0-1-2-3).

If, on the other hand, the letter F appears, this means that operation of the electrostatic cell is not correct.

The reason may be a deposit of pollutant on the surface of the ionisation wires (see paragraph "ELECTRONIC CIRCUIT ALARM SIGNALS").

If the letter F appears together with the indication ALARM, the operation of the Revitaliser does not stop, however it is an indication of efficiency reduction.



7.1.2 RECEIVER



The receiver permits the reception of the signal coming from the infrared remote control unit to obtain speed changes, activation of the night-time deodorization phase or switching off of the apparatus; if one of the four remote control buttons has been pressed, the Led flashes for about 1 second.

7.1.3 MANUAL, TEST, ON-OFF FILTER AND RESET BUTTONS

The MANUAL button allows the air flow to be modified manually (0-1-2-3); the setting is memorised and maintained even if there is a power failure. The machine can be turned off by turning to flow 0 (fan off).



Pressing the button indicated, a test on the operation of the electronic circuit signals is carried out. The air purifier is in perfect operating conditions only if all the Leds go on. Otherwise call our service network.



The ON/OFF button is for activating/deactivating the filtration or revitalisation function. It is used when you need to completely dry the filtering unit after washing, or to use the machine for the ventilation function only.



The RESET button is for turning off the ALARM signal if the circuit protection device has tripped as a result of a continuous discharge or short circuit in the electrostatic cells. If the alarm persists even after resetting, call the technical service.



7.1.4 OPERATION OF THE MACHINE

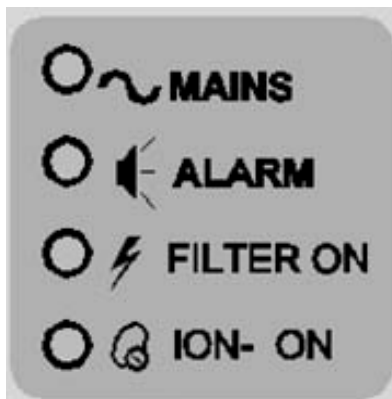

These four LEDs indicate the operating status of the environmental Revitalizer:

- MAINS (green Led): power on (constant)
- ALARM (red Led): when this is on, it means that there is a problem with the high-efficiency filtration unit. All the filtration and revitalisation functions are stopped (call the technical service).
- FILTER ON (yellow Led): when this is on, it means that filtering is on.
- ION- ON (yellow Led): when this is on, it means that revitalisation is on (ionic re-equilibrium).

7.1.5 FILTERING STATUS

The three Leds indicate the state of filtering efficiency and therefore only go on when filtration is activated; only one Led lights up at a time. The indications on filtering status are:

	<p>- MAINTENANCE (red Led):</p>	<p>saturated filter to be cleaned or replaced (maintenance); in this case all the filtering and revitalisation functions are stopped.</p>
	<p>- PRE-ALARM (yellow Led):</p>	<p>efficient filtering but not at the maximum levels (pre-alarm)</p>
	<p>- FILTER OK (green Led):</p>	<p>high filtering efficiency</p>

7.2 INFRARED REMOTE CONTROL UNIT

The remote control unit allows you to control the Revitalizer, modifying the air flow and activating night-time revitalisation from a distance of about 6-7 metres. The following functions are provided:

- 1st FAN SPEED key: sets the "maintenance" flow (room half empty)
- 2nd FAN SPEED key: sets the "normal use" flow (room half-full)
- 3rd FAN SPEED key: sets the "emergency" flow (room crowded)
- OFF key: turns off the air purifier

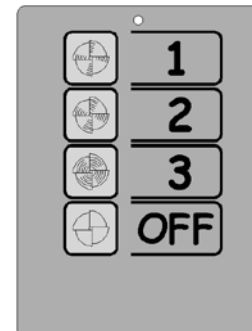

How to use: point the remote control towards the control panel, taking care that you are in line with it at a distance no greater than 6-7 metres.

When one of the four keys is pressed, the red LED at the top of the remote control unit goes on to indicate that transmission is in progress. Almost at the same time, the red LED located in the receiver of the control panel flashes, indicating that the signal has been received.

The infrared transmitter is powered by a 9-volt battery, type PP3 (transistor).

7.3 POWER SUPPLY AND ANTI BLACK-OUT SYSTEM

The machine is powered by a mains voltage of 210 to 240V AC at 50 Hz.

A momentary (or prolonged) power failure does not cause the resetting of the machine functions and when power is restored the machine goes back into operation on its own.

ATTENTION: always connect the apparatus to the earth to protect persons, things and animals and respect CEI 11-29, CEI 64-8, and EN 60335 standards.

7.4 ENVIRONMENTAL REVITALISATION (RIVITALIZZAZIONE AMBIENTALE®)

The Revitalizer revitalises the air in a confined environment in a completely automatic manner and until the pollutant has been completely cleaned from the environment.

This phase is automatically activated after the complete purification of the air so that the phenomenon of electrostatic charging of the pollutants cannot occur as they would be deposited on the walls, on the furnishings and in the respiratory tract. The revitalisation of the air is for re-establishing the ionic equilibrium in the environment after all the pollutants have been cleansed from it.

During the normal operation of this phase, the yellow led ION-ON lights up with fixed light.

Table A Advantages of negative ionisation

ASPECTS INVOLVED	EFFECTS PRODUCED
Air quality	Improvement
Odours	Reduction
Arterial pressure	Reduction
Cardiovascular system	Improvement
Metabolism	Increase
Allergies	Reduction
Respiratory capacity	Improvement
Insomnia	Reduction
Mental concentration	Increase

The Revitalizer only goes off when the user turns the operating capacity to 0 by means of the control panel or the remote control unit, or if an alarm trips due to malfunction arising from problems in the electrostatic cells or in the electronic parts (ALARM, MAINTENANCE). In this case only the fan works.

7.5 PURIFICATION

The Revitalizer purifies the air by means of a high-efficiency electrostatic filter whose operation is governed by an electronic circuit which guarantees optimal and constant performance with time in any situation.

7.6 NORMAL CONDITIONS OF OPERATION

In normal conditions of operation the Revitalizer alternates the purification phase with the revitalisation phase, so that the environmental conditions described above can be created.

The purification phase is indicated by the yellow FILTER-ON and the green FILTER-OK Leds lighting up, while the revitalisation phase is shown by the yellow Led ION-ON lighting up (without flashing).

7.7 NIGHT-TIME REVITALISATION WITH ENVIRONMENTAL DEODORIZATION

If the Revitalizer is off or in flow position 2 or 3, this phase is activated by pressing button 1 of the infrared remote control unit three times consecutively, while if the flow is 1, the button should be pressed twice. During this phase, night revitalisation is signalled by the flashing of the yellow ION-ON and FILTER ON leds, and must only be used during the period when the premises are not occupied by people.

After this activation it is possible to change the fan speed.

The benefits which can be found with night-time revitalisation are especially evident the following morning when an air quality at a level never found before will be noted.

Night-time revitalisation must be turned off in the morning by pressing the OFF button on the remote control unit or turning the display to 0 (zero) by means of the MANUAL button; then activate the daytime operating phase by turning the Revitalizer to one of the 3 speeds available, by means of the remote control unit or the MANUAL button.

7.8 SIGNALS

The electronic control of this apparatus provides the user visually with all the information on operation required for correct use, and makes available the means for fast checking to seek any small anomalies, by means of the RESET-TEST-ON/OFF FILTER buttons.

7.9 STATE OF FILTRATION EFFICIENCY

As described in paragraph CONTROL PANEL, the three Leds of FILTRATION STATUS provide indications on the state of filtration efficiency.

The environmental revitalisation cycle remains active until optimal air filtration is obtained, indicated by the FILTER OK or PRE-ALARM Leds. If optimal filtration is not guaranteed, the red Led MAINTENANCE, will go on and the automatic revitalisation cycle will be deactivated (FILTER ON and/or ION-ON Leds off). In this case only the electric fan will run.

To turn off the alarm, simply turn off the Revitalizer, turning it to 0 (zero), and then start it again at any one of the three speeds; if the operating condition with the red MAINTENANCE Led persists, carry out a general check of the filtering system, see ORDINARY MAINTENANCE.

7.10 OPTIMAL APPLICATION OF THE REVITALIZER

NATURE SYSTEM® guarantees restoration of the conditions of purity and ionic re-equilibrium in all contaminated environments. You get the maximum results with NATURE SYSTEM® if you first identify the particular type of problem the Revitalizer must solve. For this reason, eight types of Revitalizer suitable for specific applications have been defined.

- TYPE **A**: suitable for premises such as bars, casinos, discos, pubs, amusement arcades, etc.
- TYPE **B**: suitable for premises such as restaurants, pizzeria, cafes, ice-cream parlours, butcher shops, etc.
- TYPE **C**: suitable for premises such as shops and stores for food, clothing, electrical appliances, etc.
- TYPE **D**: suitable for premises such as offices, computer rooms, professional offices, waiting rooms, laboratories, etc.
- TYPE **E**: suitable for premises such as hospital wards, and for treating illnesses of the respiratory tract, allergies, etc.
- TYPE **F**: suitable for environments in built-up areas and with high environmental pollution
- TYPE **G**: suitable for environments with high radon concentrations
- TYPE **H**: suitable for garden nurseries, flower shops and flower-growing in general

7.11 ELECTRONIC CIRCUIT ALARM SIGNALS

The electronic circuit detects every cause of imperfect air filtration. If there is a slight drop in the efficiency of the machine, the yellow PRE-ALARM Led will light up. If, however, the drop in efficiency is greater, filtering will be blocked completely and the red MAINTENANCE Led will go on. These signals can also come on because of faults in the physical state of the electrostatic cells.

TYPE OF ALARM	CAUSE	OPERATION
yellow LED on PRE-ALARM or letter F on the display	electrostatic cell dirty	carry out normal maintenance
yellow LED on PRE-ALARM	electrostatic cell not properly clean	if small dirty areas have remained, washing must be carried out again
yellow LED on PRE-ALARM	electrostatic cell damp	dry the cell thoroughly and particularly in the zone of the insulators
yellow LED on PRE-ALARM	electrostatic cell not properly rinsed	there may be detergent on the insulators; the cell must be thoroughly rinsed again
yellow LED on PRE-ALARM	small bodies trapped between the collection blades	the foreign bodies deposited on the blades must be removed
red LED on MAINTENANCE	electrostatic cell very dirty	carry out normal maintenance as soon as possible
red LED on MAINTENANCE and ALARM	electrostatic cell very dirty because of breakage of an ionisation wire	the wire must be removed and replaced immediately
red LED on MAINTENANCE and ALARM	electrostatic cell short circuited due to collection blade being bent	the blade must be straightened (call a specialised technician)
red LED on MAINTENANCE and ALARM	electrostatic cell short circuited by body trapped between the blades	the body must be removed taking care not to break the ionisation wires
letter F on the display	ionisation wires dirty or oxidised	clean the wires with a rag soaked in alcohol; if the problem persists, the wires must be replaced

It is possible that the operating status of the Revitalizer can be modified with some infrared remote control units for television sets or banknote readers for videogames by modifying the speed fan and the status of the machine. Check that this does not happen by pointing the TV remote control at the Revitalizer and press the ON/OFF button.

7.12 ELECTRONIC CIRCUIT ANOMALOUS SIGNALS

In some cases signals such as the following may occur:

- the display goes off momentarily,
- the letter 'P' on the display goes on,
- the letter 'N' on the display goes on.

The first case is the automatic circuit protection tripping when ionisation voltage has been discharged to the earth. In this case, it is necessary to check that the pre-filter is properly fitted in its seat and that it does not oscillate when the Revitalizer is working.

The other two cases are due to activation of particular test programs due to the simultaneous pressure of two buttons on the control panel of the circuit. To eliminate this activation, first disconnect the power plug and wait 5-10 seconds before putting it back in.

If the electronic circuit is damaged, fault signals of the following kind may occur:

- more than one of the filter efficiency Leds go on at the same time
- fan runs without any speed indication on the display
- no fan speed variation or fan fails to run
- the ALARM and MAINTENANCE Leds go on with indication of the operating speed without the filter cell being inserted.

In these cases you must call the nearest service centre.

8

AFC SYSTEM®

AFC SYSTEM®

The system automatically carries out all the controls and gives the commands to the high-efficiency filtration along with the information required on the operating status of the apparatus.

Infrared remote control unit

The remote control unit allows the user to control the operation of the machine from a distance of about 6÷7 metres; in particular, the air flow can be varied.

High-efficiency filtration unit

This element feeds the filtering System in a completely automatic manner, maintaining constant high efficiency in all situations.

8.1 CONTROL PANEL

All information regarding the operating status of the machine is displayed on the control panel.

The control panel allows the user to:

- select the air flow
- turn off any alarms indicating apparatus malfunctions
- constantly control all the functions relating to operation (air flow, filtration efficiency, alarm situation).

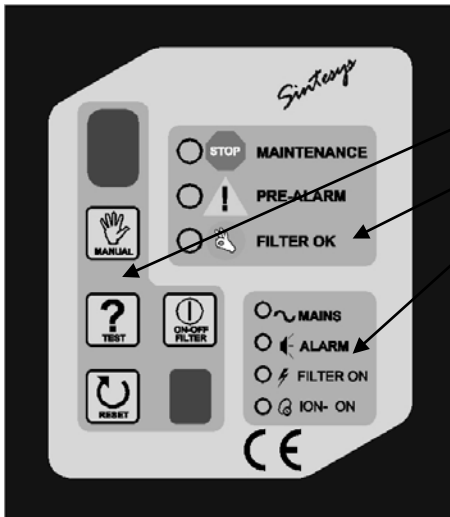

The control panel is divided in three zones:
 1 – COMMANDS AND VISUALISATION OF THE SPEED
 2 – FILTERING STATUS
 3 – OPERATION OF THE APPARATUS

The devices which permit manual operation and visual control of the operating conditions are given here below.

8.1.1 DISPLAY

When the machine works normally, the single-figure display shows the operating air flow (0-1-2-3).

If, on the other hand, the letter F appears, this means that operation of the electrostatic cell is not correct. The reason may be a deposit of pollutant on the surface of the ionisation wires (see paragraph "ELECTRONIC CIRCUIT ALARM SIGNALS").

If the letter F appears together with the indication ALARM, the operation of the machine does not stop, however it is an indication of efficiency reduction.



8.1.2 (RECEIVER)



The receiver permits the reception of the signal coming from the infrared remote control unit to obtain speed changes or switching off of the apparatus; if one of the four remote control buttons has been pressed, the Led flashes for about 1 second.

8.1.3 MANUAL, TEST, ON-OFF FILTER AND RESET BUTTONS

The MANUAL button allows the air flow to be modified manually (0-1-2-3); the setting is memorised and maintained even if there is a power failure. The machine can be turned off by turning to flow 0 (fan off).



Pressing the button indicated, a test on the operation of the electronic circuit signals is carried out. The air purifier is in perfect operating conditions only if all the Leds go on. Otherwise call our service network.



The ON/OFF button is for activating/deactivating the filtration function. It is used when you need to completely dry the filtering unit after washing, or to use the machine for the ventilation function only.



The RESET button is for turning off the ALARM signal if the circuit protection device has tripped as a result of a continuous discharge or short circuit in the electrostatic cells. If the alarm persists even after resetting, call the technical service.



8.2 OPERATION OF THE MACHINE



These four Leds indicate the operating status of the Air Purifier:



- MAINS (green Led): power on (constant)
- ALARM (red Led): When this is on, it means that there is a problem with the high-efficiency filtration unit. All the filtration functions are stopped (call the technical service).
- FILTER ON (yellow Led): When this is on, it means that filtering is on.
- ION- ON (yellow Led): **This function is not available in AFC System version.**

8.3 FILTERING STATUS

The three Leds indicate the state of filtering efficiency and therefore only go on when filtration is activated; only one Led lights up at a time. The indications on filtering status are:

	<p>- MAINTENANCE (red Led):</p>	<p>saturated filter to be cleaned or replaced (maintenance); in this case all the filtering functions are stopped.</p>
	<p>- PRE-ALARM (yellow Led):</p>	<p>efficient filtering but not at the maximum levels (pre-alarm)</p>
	<p>- FILTER OK (green Led):</p>	<p>high filtering efficiency</p>

8.4 INFRARED REMOTE CONTROL UNIT

The remote control unit allows you to control the machine, modifying the air flow from a distance of about 6-7 metres. The following functions are provided:

- 1st FAN SPEED key: sets the "maintenance" flow (room half empty)
- 2nd FAN SPEED key: sets the "normal use" flow (room half-full)
- 3rd FAN SPEED key: sets the "emergency" flow (room crowded)
- OFF key: turns off the air purifier

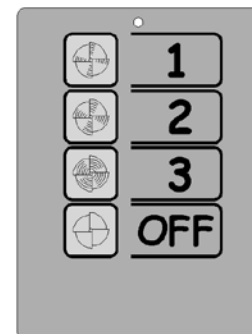

How to use: point the remote control towards the control panel, taking care that you are in line with it at a distance no greater than 6-7 metres.

When one of the four keys is pressed, the red LED at the top of the remote control unit goes on to indicate that transmission is in progress. Almost at the same time, the red LED located in the receiver of the control panel flashes, indicating that the signal has been received.

The infrared transmitter is powered by a 9-volt battery, type PP3 (transistor).

8.5 POWER SUPPLY AND ANTI BLACK-OUT SYSTEM

The machine is powered by a mains voltage of 210 to 240V AC at 50 Hz.

A momentary (or prolonged) power failure does not cause the resetting of the machine functions and when power is restored the machine goes back into operation on its own.

ATTENTION: always connect the apparatus to the earth to protect persons, things and animals and respect CEI 11-29, CEI 64-8, and EN 60335 standards.

8.6 PURIFICATION

The Air Purifier purifies the air by means of a high-efficiency electrostatic filter whose operation is governed by an electronic circuit which guarantees optimal and constant performance with time in any situation.

8.7 SIGNALS

The electronic control of this apparatus provides the user visually with all the information on operation required for correct use, and makes available the means for fast checking to seek any small anomalies, by means of the RESET - TEST - ON/OFF FILTER buttons.

8.8 STATE OF FILTRATION EFFICIENCY

As described in paragraph CONTROL PANEL, the three Leds of FILTRATION STATUS provide indications on the state of filtration efficiency.

The purifying cycle remains active until optimal air filtration is obtained, indicated by the FILTER OK or PRE-ALARM Leds. If optimal filtration is not guaranteed the red Led MAINTENANCE will go on (Led FILTER ON off). In this case only the electric fan will run.

To turn off the alarm, simply turn off the machine, turning it to 0 (zero), and then start it again at any one of the three speeds; if the operating condition with the red MAINTENANCE Led persists, carry out a general check of the filtering system, see ORDINARY MAINTENANCE.

8.9 ELECTRONIC CIRCUIT ALARM SIGNALS

The electronic circuit detects every cause of imperfect air filtration. If there is a slight drop in the efficiency of the machine, the yellow PRE-ALARM Led will light up. If, however, the drop in efficiency is greater, filtering will be blocked completely and the red MAINTENANCE Led will go on. These signals can also come on because of faults in the physical state of the electrostatic cells.

TYPE OF ALARM	CAUSE	OPERATION
yellow LED on PRE-ALARM or letter F on the display	electrostatic cell dirty	carry out normal maintenance
yellow LED on PRE-ALARM	electrostatic cell not properly clean	if small dirty areas have remained, washing must be carried out again
yellow LED on PRE-ALARM	electrostatic cell damp	dry the cell thoroughly and particularly in the zone of the insulators
yellow LED on PRE-ALARM	electrostatic cell not properly rinsed	there may be detergent on the insulators; the cell must be thoroughly rinsed again
yellow LED on PRE-ALARM	small bodies trapped between the collection blades	the foreign bodies deposited on the blades must be removed
red LED on MAINTENANCE	electrostatic cell very dirty	carry out normal maintenance as soon as possible
red LED on MAINTENANCE and ALARM	electrostatic cell very dirty because of breakage of an ionisation wire	the wire must be removed and replaced immediately
red LED on MAINTENANCE and ALARM	electrostatic cell short circuited due to collection blade being bent	the blade must be straightened (call a specialised technician)
red LED on MAINTENANCE and ALARM	electrostatic cell short circuited by body trapped between the blades	the body must be removed taking care not to break the ionisation wires
letter F on the display	ionisation wires dirty or oxidised	clean the wires with a rag soaked in alcohol; if the problem persists, the wires must be replaced

It is possible that the operating status of the machine can be modified with some infrared remote control units for television sets or banknote readers for videogames by modifying the speed fan and the status of the machine. Check that this does not happen by pointing the TV remote control at the Air Purifier and press the ON/OFF button.

8.10 ELECTRONIC CIRCUIT ANOMALOUS SIGNALS

In some cases signals such as the following may occur:

- the display goes off momentarily,
- the letter 'P' on the display goes on,
- the letter 'N' on the display goes on.

The first case is the automatic circuit protection tripping when ionisation voltage has been discharged to the earth. In this case, it is necessary to check that the pre-filter is properly fitted in its seat and that it does not oscillate when the machine is working.

The other two cases are due to activation of particular test programs due to the simultaneous pressure of two buttons on the control panel of the circuit. To eliminate this activation, first disconnect the power plug and wait 5-10 seconds before putting it back in.

If the electronic circuit is damaged, fault signals of the following kind may occur:

- more than one of the filter efficiency Leds go on at the same time
- fan runs without any speed indication on the display
- no fan speed variation or fan fails to run
- the ALARM and MAINTENANCE Leds go on with indication of the operating speed without the filter cell being inserted.

In these cases you must call the nearest service centre.

9

BASIC SYSTEM

BASIC SYSTEM

The System carries out the controls and gives the commands for filtration and negative ionisation along with the information required on the operating status of the apparatus.

Infrared remote control unit

The remote control unit allows the user to control the operation of the machine from a distance of about 6÷7 metres; in particular, the air flow can be varied.

Negative ionisation

The BASIC SYSTEM allows a continually, negative environmental ionisation.

9.1 CONTROL PANEL

For modifying the operating status of the machine it is possible to use the control panel or the remote control. All information regarding the operating status of the machine is displayed on the control panel.

The control panel allows the user to:

- select the air flow
- control of all the functions relating to operation (air flow, filter on, alarm situation).

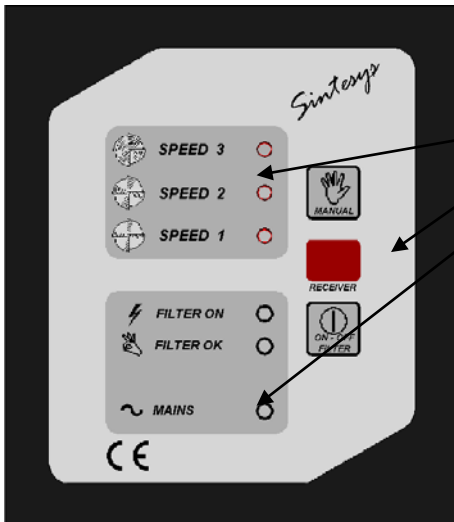

The control panel is divided in three zones:
 1 – VISUALISATION OF THE SPEED
 2 – FILTERING COMMANDS
 3 – OPERATION OF THE APPARATUS

The devices which permit manual operation and visual control of the operating conditions are given here below.

9.2 VISUALISATION OF SPEED

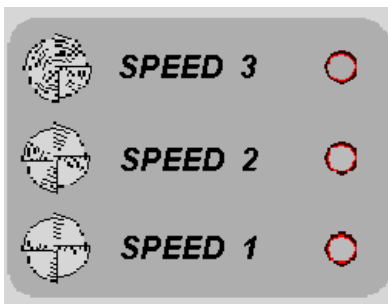

The control panel shows the speed of the machine by lighting on the yellow Led corresponding to:
 speed 3 (fast), speed 2 (medium), speed 1 (slow)

9.2.1 RECEIVER



The receiver permits the reception of the signal coming from the infrared remote control unit to obtain speed changes, if one of the four remote control buttons has been pressed, the Led of receiver will be on.

9.2.2 MANUAL AND ON-OFF FILTER BUTTONS

The MANUAL button allows the air flow to be modified manually (OFF-1-2-3); the setting is memorised and maintained even if there is a power failure.



The ON/OFF button is for activating/deactivating the filtration function and the negative ionisation. It is used when you need to completely dry the filtering unit after washing, or to use the machine for the ventilation function only.



9.3 OPERATION OF THE MACHINE

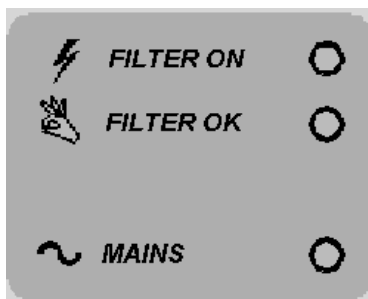

These three Leds indicate the operating status of the Air Purifier:

- FILTER ON (yellow led): when this is on, it means that filtering and ionisation are on.
- FILTER OK (green led): high filtering efficiency and emission of ions
- MAINS (green led): power on (constant)

9.4 INFRARED REMOTE CONTROL UNIT

The remote control unit allows you to control the machine, modifying the air flow from a distance of about 6-7 metres. The following functions are provided:

- 1st FAN SPEED key: sets the "maintenance" flow (room half empty)
- 2nd FAN SPEED key: sets the "normal use" flow (room half-full)
- 3rd FAN SPEED key: sets the "emergency" flow (room crowded)
- OFF key: turns off the air purifier

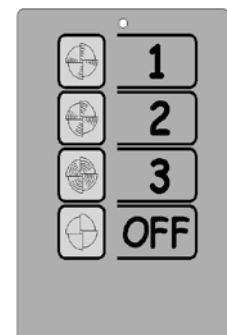

How to use: point the remote control towards the control panel, taking care that you are in line with it at a distance no greater than 6-7 metres.

The infrared transmitter is powered by a 9-volt battery, type PP3 (transistor).

9.5 POWER SUPPLY AND ANTI BLACK-OUT SYSTEM

The machine is powered by a mains voltage of 210 to 240V AC at 50 Hz.

A momentary (or prolonged) power failure does not cause the resetting of the machine functions and when power is restored the machine goes back into operation on its own.

ATTENTION: always connect the apparatus to the earth to protect persons, things and animals and respect CEI 11-29, CEI 64-8, and EN 60335 standards.

9.6 PURIFICATION

The Air Purifier purifies the air by means of a high-efficiency electrostatic filter whose operation is governed by an electronic circuit.

9.7 SIGNALS

The electronic control of this apparatus provides the user visually with all the information on operation required for correct use, and makes available the means for fast checking to seek any small anomalies.

9.8 STATUS OF FILTRATION EFFICIENCY

The environmental air cleaning cycle remains active until the Led FILTER OK is on. If optimal filtration is not guaranteed, the Led FILTER OK starts to flash. In this case only the electric fan will run.

It is necessary to carry out a general maintenance check of the filtering system, for that see paragraph ORDINARY MAINTENANCE.

9.9 ELECTRONIC CIRCUIT ALARM SIGNALS

The electronic circuit will light up an eventually block of filtration. The causes often can be resolved by a small operation.

TYPE OF ALARM	CAUSE	OPERATION
green Led FILTER OK is flashing	electrostatic cell dirty	carry out normal maintenance
	electrostatic cell not properly clean	if small dirty areas have remained, washing must be carried out again
	electrostatic cell damp	dry the cell thoroughly and particularly in the zone of the insulators
	electrostatic cell not properly rinsed	there may be detergent on the insulators; the cell must be thoroughly rinsed again
	small bodies trapped between the collection blades	the foreign bodies deposited on the blades must be removed
	electrostatic cell short circuited due to breakage of an ionisation wire	the wire must be removed and replaced immediately
	electrostatic cell short circuited due to collection blade being bent	the blade must be straightened (call a specialised technician)

It is possible that the operating status of the machine can be modified with some infrared remote control units for television sets or banknote readers for videogames by modifying the speed fan and the status of the machine. Check that this does not happen by pointing the TV remote control at the Air Purifier and press the ON/OFF button.

10 TECHNICAL DATA

model	capacity m ³ /h	dB	Watt	aliment. V - Hz	dimensions mm	weight kg	n° of cells	kind of installation	remote control
50P	1 ^a veloc. 300 2 ^a veloc. 440 3 ^a veloc. 550	37 40 50	95	230 – 50	5488x370x302	20,5	1	supporting	YES

11 CERTIFICATIONS

All machines are in possession of certification which attests to the high quality of the air treated and the high quality of the materials used to build them.

11.1 CERTIFICATION C.N.R.

The machines are in possession of C.N.R. certification, which attests to the efficiency of filtration declared for each model and certifies that ozone production is much lower than the limits laid down in law. For further clarification or to receive this certification, contact the manufacturer.

11.2 CERTIFICATION OF COMPONENTS

The electrical components used for the construction are being certified or are in possession of ISO29000 and quality certification meeting the requisites of current standards for electrical and mechanical safety, in accordance with EEC Machine Directive 89/392.