



- No spring return
- Running time 150 sec
- 40 Nm
- Modulating 2...10Vcc?
- Power supply 24V ac, 24V dc
- According to EN 60079-0,EN60079-1,
- EN 60079-31
- Zones 1, 2, 21, 22

**Applications**

The EXAM...GM actuators are intended for the operation of air control damper in ventilation and air condition systems up to approx 8m<sup>2</sup>.

**Features**

Just powered, the actuator moves the damper to its start position, then it moves to the position set by the control signal.

The actuator is overload protected. The actuator can be mounted directly on the damper shaft if square, 12 x 12 mm or 10 x 10 mm (adaptor included);

Several mounting brackets are available for applications where the actuator cannot be directly coupled to the damper shaft. The cable glands are fit for cable diameters from 8 to 10,5 mm.



NEMKO 03 ATEX 1242X

- Ex II 2G Ex d IIC T6 Gb
  - Ex II 2D Ex tb IIIC T67 °C
- For zone 1, 2, 21, 22

The product may differ from the illustration

ITEM	Auxiliary Switch
EXAM G B MF2 0 L 000	0
EXAM G B MF2 0 R 000	
EXAM G B MF2 2 L 000	2 x SPDT
EXAM G B MF2 2 R 000	
EXAM G B MF1 0 L 000	2 x SPDT
EXAM G B MF1 0 R 000	
EXAM G B MF1 2 L 000	2 x SPDT
EXAM G B MF1 2 R 000	
EXAM G B MF5 0 L 000	0
EXAM G B MF5 0 R 000	
EXAM G B MF5 2 L 000	2 x SPDT
EXAM G B MF5 2 R 000	

- Options available on request:
- Different angle of rotation
  - Different wiring length

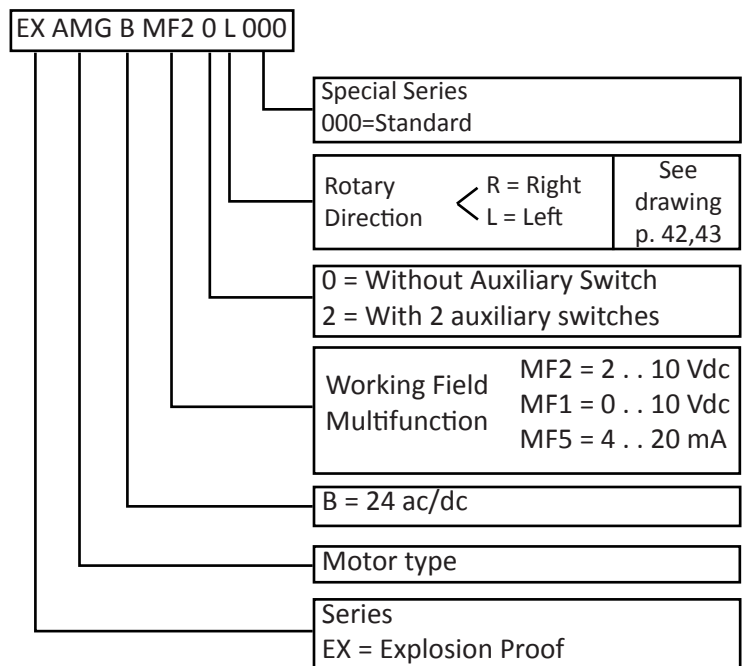



## Technical data

Torque	40 Nm
Power supply	AC 24V 50/60Hz, DC 24V
Nominal voltage range	AC/DC 19.2 ... 28.8V
Power consumption: running	5.0 W
Power consumption: at rest	2.0 W
Sizing	7.0 VA
Rotation angle	95°
Running time	150 Sec.
Ambient temperature	-20°C + 50°C
Degree of protection	IP66
Housing material	Aluminium baked varnish
Maintenance	None
Fastening	Terminal block in Ex e box (optional)
Wiring length	1m cable
Weight	6.0 kg
Auxiliary switches	3A (0,5A) max 250V
	switching point 5° e 85°
EMC	CE according to 2004/108/EC
Low voltage directive	CE according to 2006/95/EEC
Halogen – Free wiring	According to IEC 60332-1/3 and According to IEC 60754-1/2

Power supply	AC 24V 50/60 Hz, DC 24V
Nominal voltage range	AC/DC 19,2...28,8 V
Power consumption: running	2.0 W
At rest	0.4 W
Sizing	4.0 VA

### Attention:

Only with MFT multifunction technology :

- Running time motor 150 s adjustable
- Control DC 2...10 V, 0...32 V adjustable
- Operating range DC 2...10 V, 0...32 V (adjustable)
- Position feedback DC 2...10 V, 0...10V, (adjustable)

### NOTE:

- Read the note about the use and torque requirements of the damper manufacturer
- All electrical wirings must be according to local standards.
- Electrical connections by power off only.
- Ex e junction box must not be opened under any circumstances when the power is on.
- Actuator cable must be installed in a fixed position and protected against damage.
- Avoid excessive vibrations.
- Before switching-on, check that no other equipment is damaged and make sure that supply voltage corresponds with the Actuator's specification.
- Before switching-off check for possible effects on other equipments.
- The Actuator cannot and is not to be opened to guarantee explosion proof and warranty.
- For any problem contact Automatikproduktur.
- The equipment shall be marked "X" since flameproof joint is other than the relevant minimum or maximum according to CEI EN 60079-1. Information on dimension of flameproof joints available at Automatikproduktur.

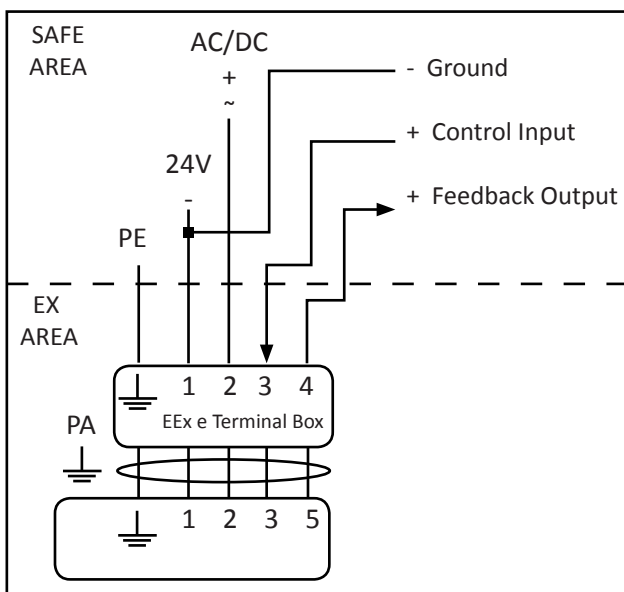

**Rotary Direction "R". For Damper normally closed N.C.**

MOTOR  
Power: ON  
Power on WIRE 2  
Control: 2 .. 10 V

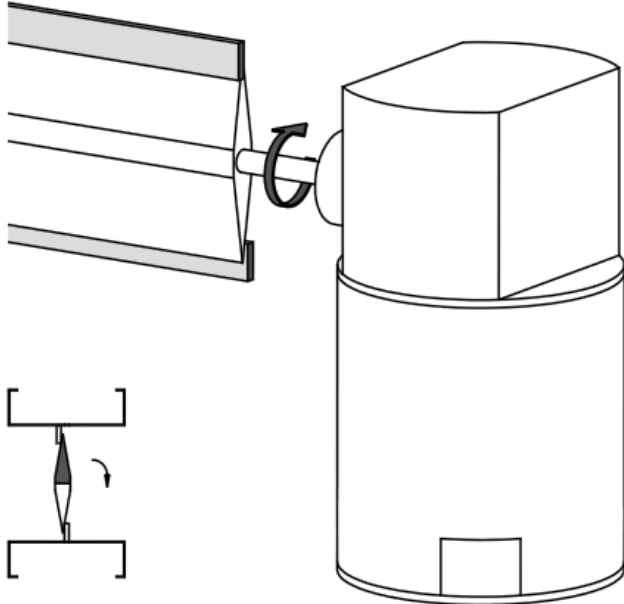

MOTOR or SPRING RETURN  
Power: OFF  
Power on WIRE 3  
Control: 10 .. 2 V

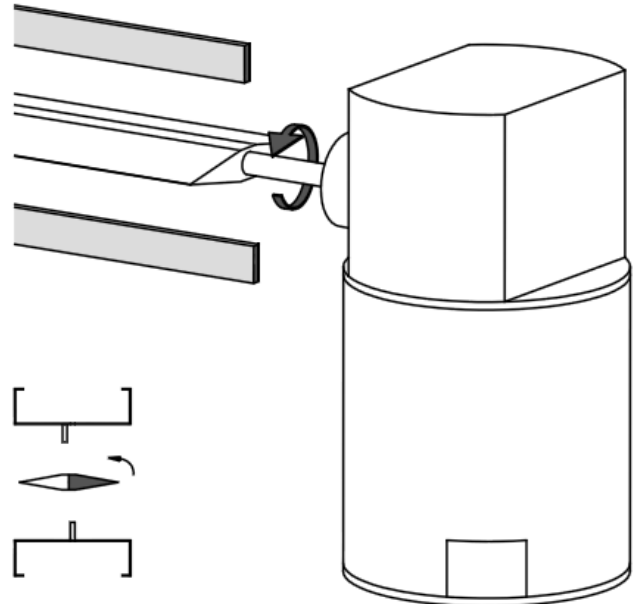

**Rotary Direction "L". For Damper normally closed N.C.**

MOTOR  
Power: ON  
Power on WIRE 2  
Control: 2 .. 10 V

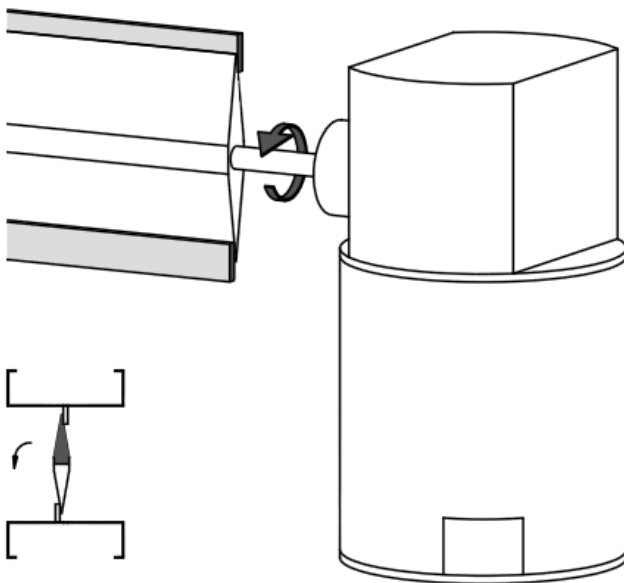

MOTOR or SPRING RETURN  
Power: OFF  
Power on WIRE 3  
Control: 10 .. 2 V

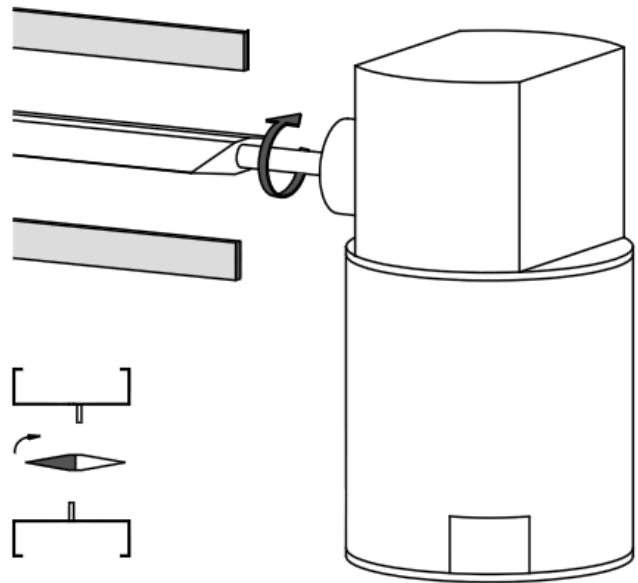

Subject to technical changes without notice. Rev. 00



**Rotary Direction "R". For Damper normally open N.O.**

MOTOR  
Power: ON  
Power on WIRE 2  
Control: 2 .. 10 V

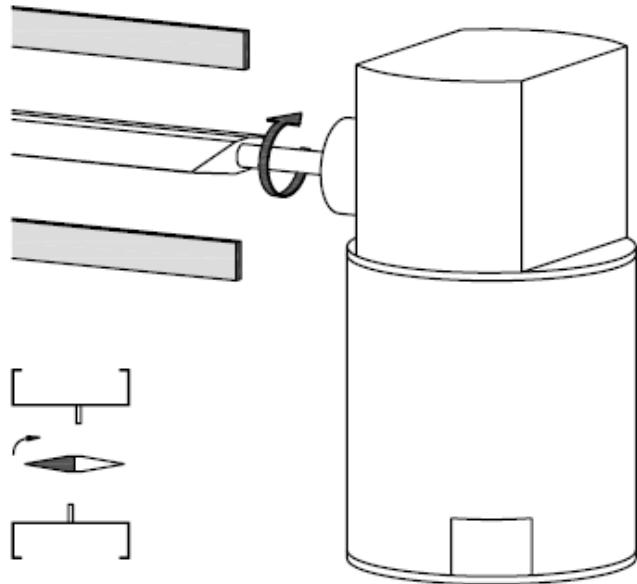

MOTOR or SPRING RETURN  
Power: OFF  
Power on WIRE 3  
Control: 10 .. 2 V

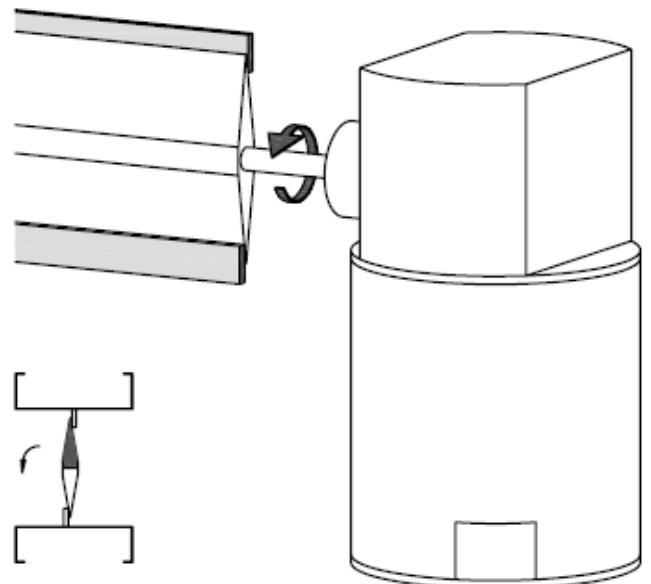

**Rotary Direction "L". For Damper normally closed N.O.**

MOTOR  
Power: ON  
Power on WIRE 2  
Control: 2 .. 10 V

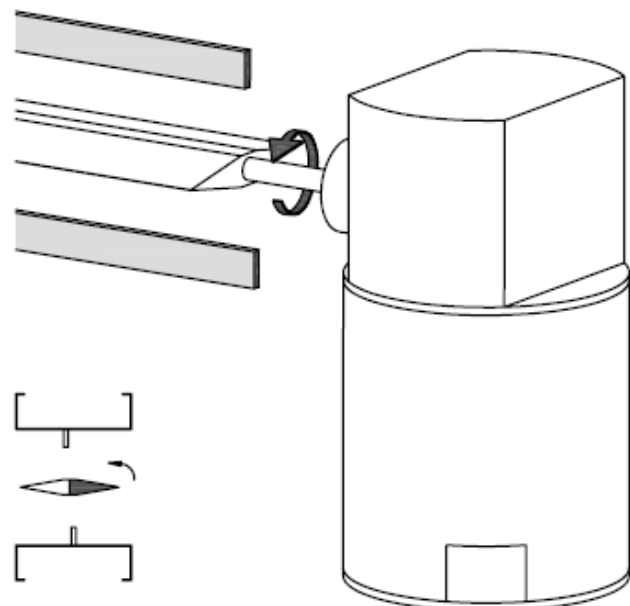

MOTOR or SPRING RETURN  
Power: OFF  
Power on WIRE 3  
Control: 10 .. 2 V

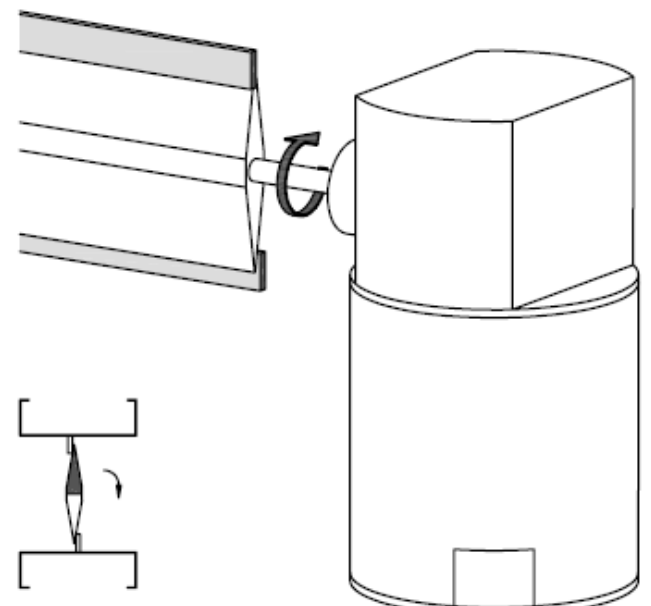

Subject to technical changes without notice. Rev. 00

Dimensions and Mounting Instructions  
EXAF - EXBF - EXBE - EXBG - EXSM - EXAM

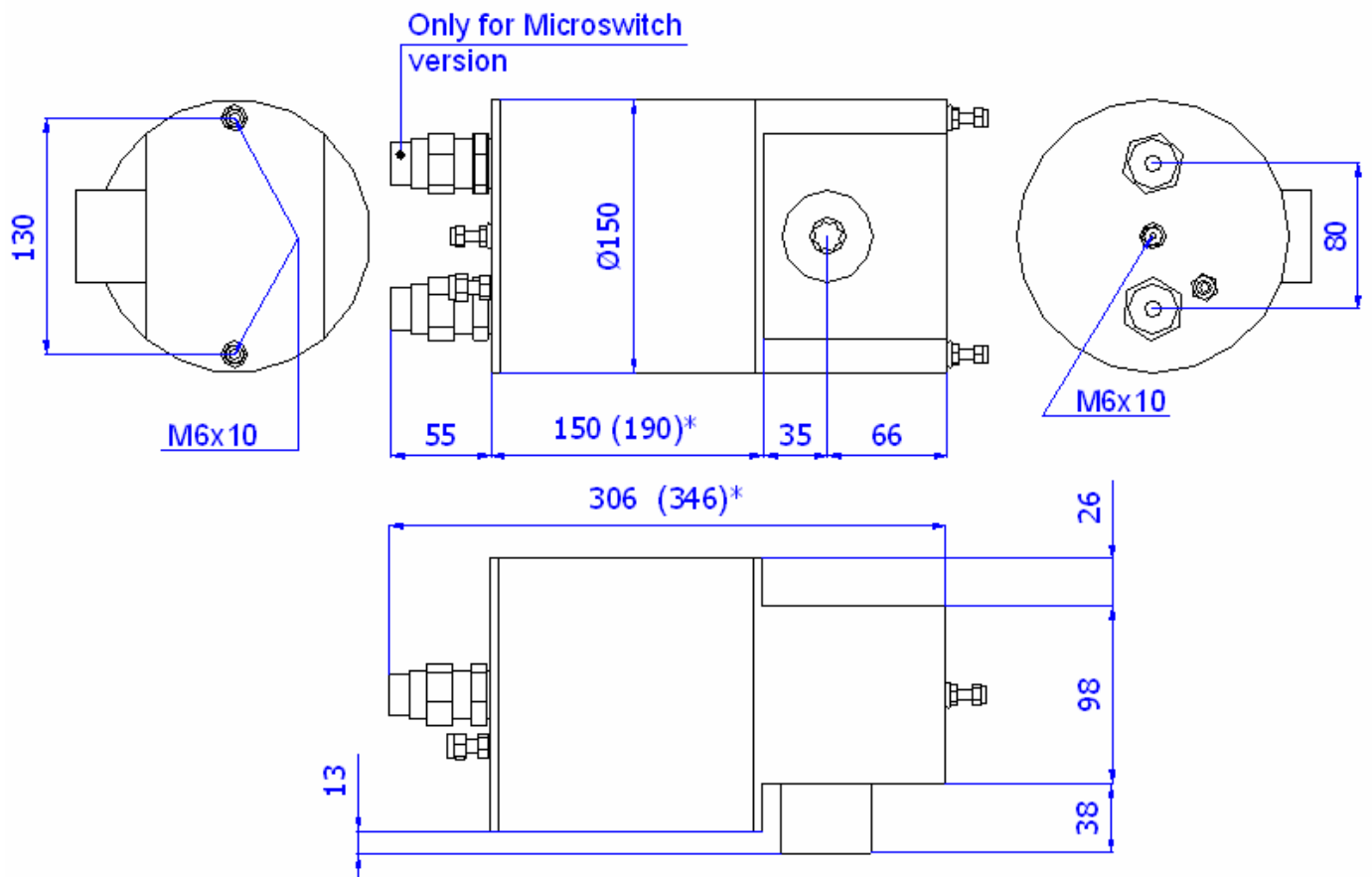

\*= Only series EXAF, EXBF, EXBG, EXBE

Note: Dimensions are specified in millimeters

EXNM

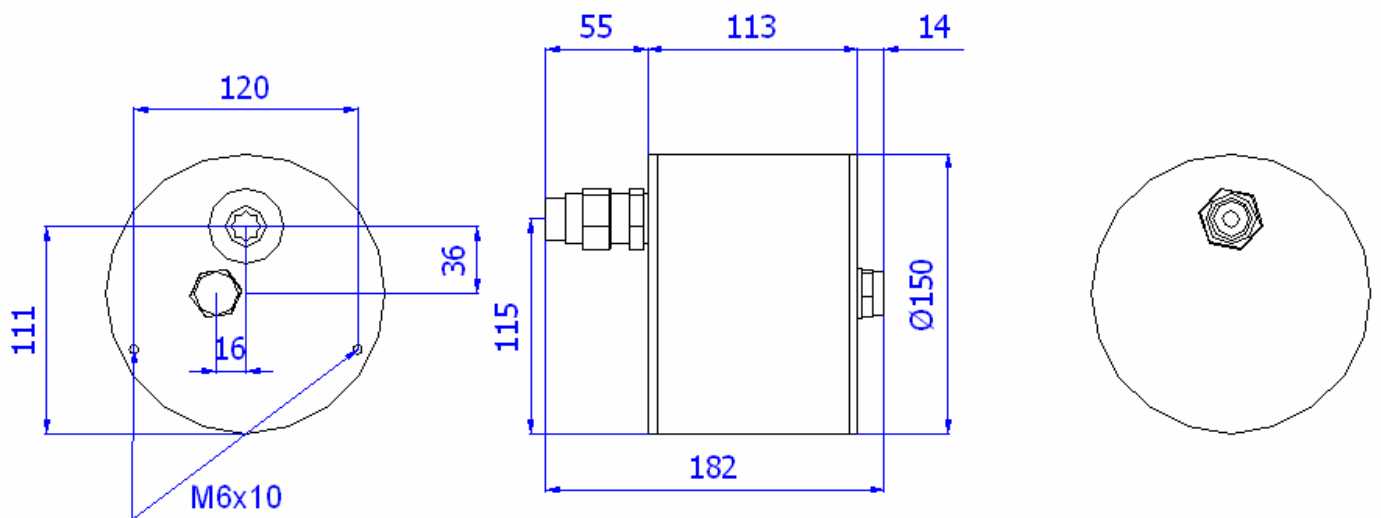

Note: Dimensions are specified in millimeters

Dimensions and Mounting Instructions  
EXAF - EXBF - EXBE - EXBG - EXSM - EXAM

Direct mount on square shaft, 12 x 12 mm

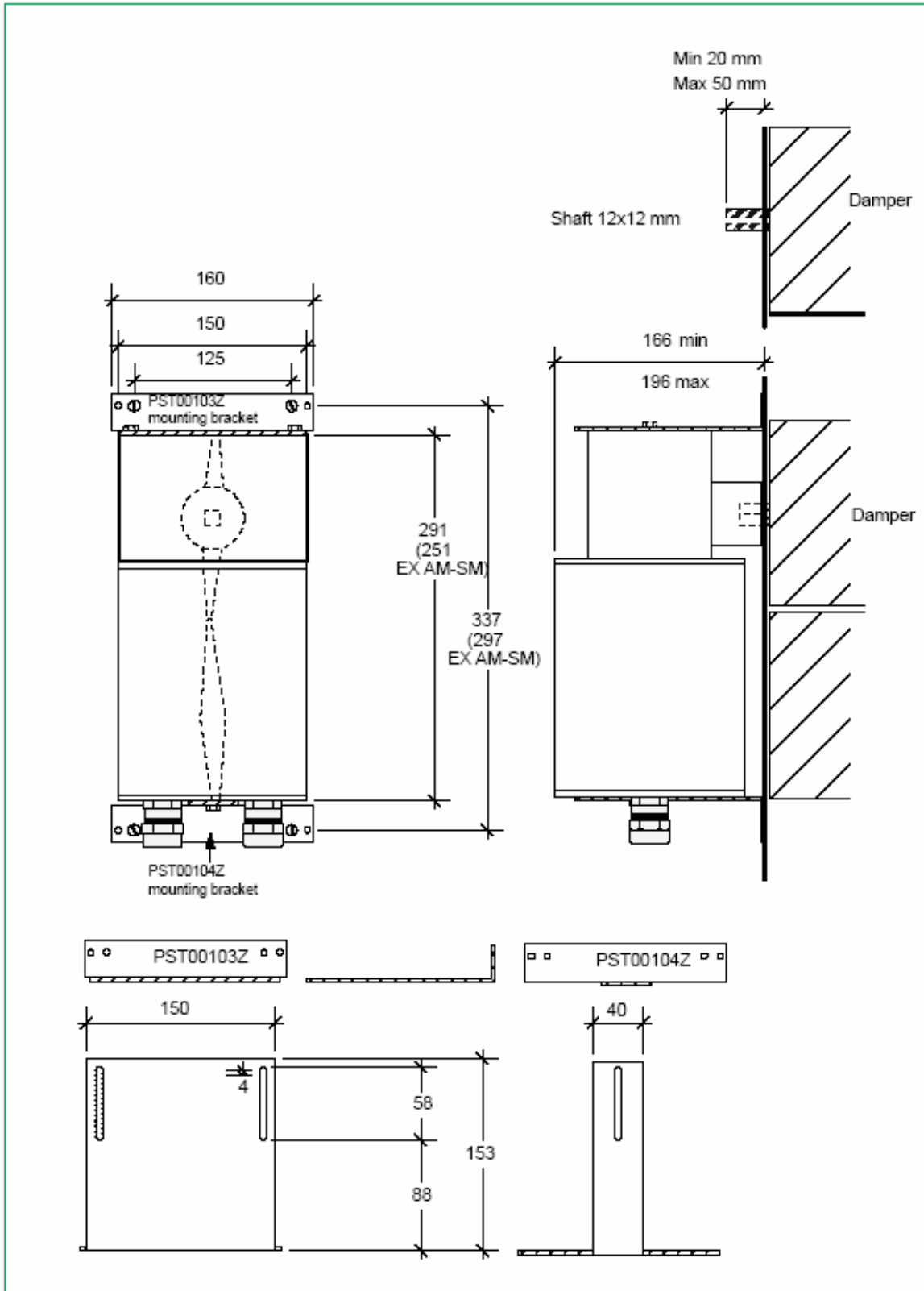

Subject to technical changes without notice. Rev: 00

Dimensions and Mounting Instructions  
EXAF - EXBF - EXBE - EXBG - EXSM - EXAM

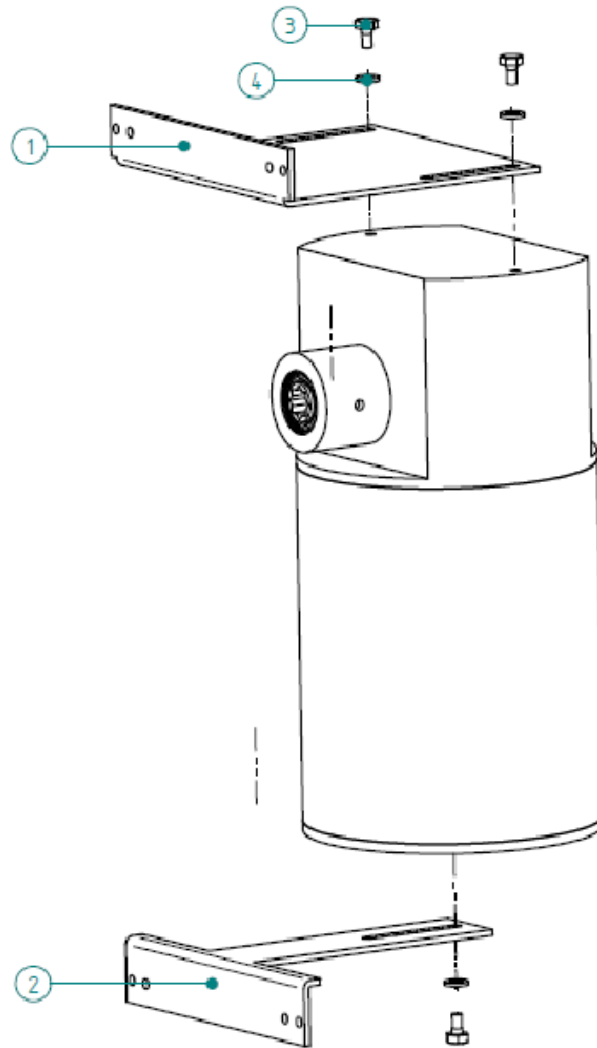

n*	Code description
1	PST00103Z
2	PST00104Z
3	TDE M6 x 10
4	Flat washer

Mount the bracket as shown in the picture above.

Threaded hole depth: 8mm. Do not replace standard screws with other one;  
or ensure that screws does not penetrate more than 7mm into the enclosure.

Flat washer dimension : Di= 6,4mm De=12mm h=1,6mm