

Electrochemical Ozone Transmitter

User Manual

March, 2009

- 1 Intended Use..... 3**
- 2 Functional Description 3**
 - 2.1 Control Mode 3
 - 2.2 Sensor 3
- 3 Installation 4**
 - 3.1 Mounting Instructions 4
 - 3.2 Installation 4
- 4 Electrical Connection 4**
 - 4.1 Wiring Connection 4
- 5 Commissioning 5**
 - 5.1 Calibration 5
 - 5.2 Manual Calibration 6
 - 5.2.1 Zero-point..... 6
 - 5.2.2 Gain 6**
 - 5.2.3 Calculation of Control Voltage 6**
 - 5.3 Calibration with GCD-05 Service Tool 7
 - 5.4 Calibration with GCD-05 Configuration and Calibration Software 7
 - 5.5 Addressing, only for GCD-05_Bus mode 8
 - 5.6 Option Relay Output..... 8
- 6 Inspection and Service 9**
 - 6.1 Inspections 9
 - 6.2 Calibration 9
 - 6.3 Exchange of Sensor Element..... 9
- 7 Troubleshooting 9**
 - 7.1 Analog Mode 9
 - 7.2 GCD-05_Bus Mode 10
- 8 Cross-sensitivity Data..... 10**
- 9 Technical Data 11**
- 10 Figures..... 13**
- 11 Notes and General Information 15**
 - 11.1 Intended Product Application..... 15
 - 11.2 Installers' Responsibilities 15
 - 11.3 Maintenance 15
 - 11.4 Limited Warranty..... 15

Electrochemical Ozone Transmitter

1 Intended Use

The O₃ analog gas transmitter with digital processing of the measuring values and temperature compensation is used for the monitoring of the ambient air to detect the presence of ozone.

The intended sites are all areas being directly connected to the public low voltage supply, e.g. residential, commercial and industrial ranges as well as small enterprises (according to EN50 082).

The O₃ analog transmitter must not be used in potentially explosive atmospheres.

The transmitter must only be used within environmental conditions specified in the Technical Data.

2 Functional Description

2.1 Control Mode

In addition to the analog output the transmitter is equipped with a serial interface RS-485 for the connection to the GCD-05 system.

Analog mode:

The analog output can be selected as current signal with (0)4-20 mA or as voltage signal (0)2-10 V.

In the 4-20 mA mode and without any supplementary options, the O3 xxx also works in the 2-wire technique.

GCD-05_Bus mode:

The transmitter can be connected to the GCD-05 system via the RS-485 interface.

In this mode there is an analog input for the connection of an additional 4-20 mA transmitter.

The two measuring values are transmitted via the RS-485 interface to the gas controller.

The cable topology for the RS-485 bus can be taken from the "Guidelines for wiring and commissioning of the GCD-05 hardware".

The two control modes are available in parallel.

2.2 Sensor

The sensor portion of the transmitter is a sealed electro-chemical cell with three electrodes, sensing, counter and reference.

The ambient air to be monitored diffuses through a membrane filter into the liquid electrolyte of the sensor. The chemical process of the measurement is one of reduction where one molecule of the target gas is exchanged for one molecule of oxygen.

The reaction drives the oxygen molecule to the counter electrode, generating a current signal (mA) between the sensing and reference electrodes.

This signal is linear to the volume concentration of the sensed gas.

The signal is evaluated by the connected amplifier and transformed into a linear output signal.

Electrochemical processes always lead by and by to a loss of sensitivity. Therefore regular calibration of zero-point and gain is obligatory. See also section 6.

Caution:

There is a small quantity of corrosive liquid in the sensor element.

If in case of damage persons or objects touch the liquid, you have to clean the affected areas as fast and carefully as possible with tap water.

Out of use sensors must be disposed in the same way as batteries.

Installation

Note:

Avoid any force (e.g. by thumb) on the sensor element during operation or installation.

Electronics can be destroyed by static electricity.

Therefore, do not touch the equipment without a wrist strap connected to ground or without standing on a conductive floor (acc. to DIN EN100015).

2.3 Mounting Instructions

When choosing the mounting site please pay attention to the following:

- The specific weight of ozone O₃ is higher than that of air (factor 1.66).
Recommended mounting height is 0.3 m (1 ft.) above floor.
- Choose mounting location of the sensor according to the local regulations.
- Consider the ventilation conditions! Do not mount the transmitter in the centre of the airflow (air passages, suction holes).
- Mount the transmitter at a location with minimum vibration and minimum variation in temperature (avoid direct sunlight).
- Avoid locations where water, oil etc. may influence proper operation and where mechanical damage might be possible.
- Provide adequate space around the sensor for maintenance and calibration work.

Duct mounting

- Mount only in a straight section of duct with minimum air vortex. Keep a minimum distance of 1 m (3.5 feet) from any curve or obstacle.
- Mount only in a duct system with a maximum air velocity of 10 m/s (2000 ft/min) or less.
- Mounting must be performed so that the probe openings are in line with the airflow.

2.4 Installation

- Open the cover.
- Mount the housing through the mounting holes at the 4 corners with the enclosed screws/ rawlplugs (sensor to the ground).
- Replace the cover.

3 Electrical Connection

Consider static electricity! See 3. Mounting

- Installation of the electrical wiring should only be executed by a trained specialist according to the connection diagram, without any power applied to conductors and according to the corresponding regulations!
- Avoid any influence of external interference by using shielded cables for the signal line, but do not connect the shield.
- Recommended cable for analog mode: J-Y(St)Y 2x2x0,8 LG (20 AWG), max. resistance 73 Ω/km (20.8 Ω/1000 ft).
- Required cable for RS-485 mode: J-Y(St)Y 2x2x0,8 LG (20 AWG), max. res. 73 Ω/km (20.8 Ω/1000 ft)
- It is important to ensure that the wire shields or any bare wires do not short the mounted PCB.

3.1 Wiring Connection

- Open the cover. Unplug basic PCB carefully from terminal blocks X4 and X5.
- Insert the cable and connect cable leads to terminal blocks. See fig. 1 and 2.
- Replug the PCB in the terminal blocks X4, X5 with care. Replace the cover.

4 Commissioning

Consider commissioning instructions at any exchange of the sensor element as well.

Only trained technicians should perform the following:

- Check mounting location.
- Select output signal form: Current or voltage, and starting point 0 or 20%. See fig. 4.
- Check power voltage.
- Check PCB AT03 for correct mounting at X4 and X5.
- Check the sensor for proper mounting at the connectors X7 of the PCB AT03.
- Addressing of the transmitter in the GCD-05_Bus mode.
- Calibrate the transmitter (if not already factory-calibrated).

Required instruments for commissioning (calibration) of the transmitter:

- Test gas bottle with synthetic air.
- Test gas bottle with O₃ (ppm) in the range of 30 – 80 % of the measuring range.
- Gas pressure regulator with flow meter to control the gas flow to 150 ml/min.
- Calibration adapter with tube. Calibration set . See fig. 5.
- Digital voltmeter with range 0 – 300 mV, accuracy 1%.
- Small screwdriver.
- Calibration tool GCD-05 STL (only for calibration with service tool GCD-05).
- GCD-05 configuration and calibration software incl. USB/RS-485 communication set (only for software calibration mode).

Note:

Prior to calibration the sensor must be connected to the power supply and fully stabilised for at least 6 hours without interruption.

Please observe proper handling procedures for test gas bottles (regulations TRGS 220)!

O₃ calibration gas is toxic, never inhale the gas!

Symptoms: Dizziness, headache and nausea.

Procedure if exposed: Take the victim into fresh air at once, call a doctor.

4.1 Calibration

Depending on the version and the control mode there are three different possibilities to calibrate the transmitter:

Manual calibration

Manual calibration is only possible if the transmitter is equipped with the push-button “Zero” and the potentiometer “Gain” (= version for manual calibration).

Manual calibration is possible both in analog mode and in GCD-05_Bus mode.

In the GCD-05_Bus mode the jumper V-A has to be set before manual calibration. Only by doing so the control voltage is available at the test pins X6. Remove the jumper after calibration

Calibration with the Service Tool GCD-05

In the standard version (equipped with the communication connector X12) the transmitter is delivered for tool and/or software calibration.

In the analog mode the service tool calibration is only possible with the 3-wire technique of the transmitter!

In the GCD-05_Bus mode calibration is always possible.

Software calibration via PC

In the standard version (equipped with the communication connector X12) calibration can also be done by means of the configuration and calibration software.

Software calibration is possible for both control modes.

4.2 Manual Calibration

5.2.1 Zero-point

- Connect calibration adapter carefully to the sensor element.
- Apply synthetic air (150 ml/min; 1 Bar (14.5 psi) ± 10%).
- Wait 2 minutes until the signal is stable, push button “Zero” for 5 seconds.
 After successful calibration the measuring signal is corrected automatically. Depending on the selected signal starting point the measuring signal shows the following values:

Signal start at 2 V or 4 mA	40 mV = 0 ppm
Signal start at 0 V or 0 mA	0 mV = 0 ppm

 If the zero-point is outside the admissible range (> 20 mV at starting point 0% / > 60 mV at starting point 20%) before calibration, there is no correction of the measuring signal. The sensor has to be replaced.
- Remove calibration adapter carefully by turning lightly. Check the sensor for correct mounting!

4.2.2 Gain

- Connect calibration adapter carefully to the sensor element.
- Apply calibration test gas O₃ (150 ml/min; 1 Bar (14.5 psi) ± 10%).
- Wait three minutes until the signal is stable, adjust control voltage with potentiometer “Gain” until the signal corresponds to the calculated value ± 2 mV, see “Calculation of Control Voltage”.
- Remove calibration adapter with a careful light turn. Check the sensor for correct mounting!
 By limiting the gain factor, calibration will not be possible any more when the sensitivity of the sensor reaches a residual sensitivity of 30 %. Then the sensor has to be replaced.

4.2.3 Calculation of Control Voltage

Signal start 2 V / 4 mA

$$\text{Control voltage (mV)} = \frac{160 \text{ (mV)} \times \text{test gas concentration O}_3 \text{ (ppm)}}{\text{measuring range O}_3 \text{ (ppm)}} + 40 \text{ (mV)}$$

Signal start 0 V / 0 mA

$$\text{Control voltage (mV)} = \frac{200 \text{ (mV)} \times \text{test gas concentration O}_3 \text{ (ppm)}}{\text{measuring range O}_3 \text{ (ppm)}}$$

Example:

Measuring range	10 ppm
Test gas concentration	5 ppm O ₃
Control voltage: Signal start 2 V / 4 mA	120 mV
Control voltage: Signal start 0 V / 0 mA	100 mV

Signal start 2 V / 4 mA

$$\frac{160 \text{ (mV)} \times 5 \text{ (ppm)}}{10 \text{ (ppm)}} + 40 \text{ (mV)} = 120 \text{ mV}$$

Signal start 0 V / 0 mA

$$\frac{200 \text{ (mV)} \times 5 \text{ (ppm)}}{10 \text{ (ppm)}} = 100 \text{ mV}$$

4.3 Calibration with GCD-05 Service Tool

- Connect the GCD-05 Service Tool to the transmitter, open menu "Calibration".
- Enter measuring range and test gas concentration.
- Connect calibration adapter carefully to the sensor element
- Apply synthetic air (150 ml/min; 1 Bar (14.5 psi) ± 10%).
- Wait until the measuring value is stable, and then perform automatic zero calibration.
- Apply calibration test gas O₃ (150 ml/min; 1 Bar (14.5 psi) ± 10%).
- Wait until the measuring value is stable, and then perform automatic gain calibration.
- Remove calibration adapter carefully by turning lightly.
- Check the sensor for correct mounting!

By limiting the gain factor, calibration will not be possible any more when the sensitivity of the sensor reaches a residual sensitivity of 30 %.

In this case the sensor has to be replaced.

Further information can be taken from the user manual of the GCD-05 Service Tool.

4.4 Calibration with GCD-05 Configuration and Calibration Software

- Connect the PC via USB/RS-485 communication set to the transmitter, open menu "Calibration".
- Enter measuring range and test gas concentration.
- Connect calibration adapter carefully to the sensor element
- Apply synthetic air (150 ml/min; 1 Bar (14.5 psi) ± 10%).
- Wait until the measuring value is stable, and then perform automatic zero calibration.
- Apply calibration test gas O₃ (150 ml/min; 1 Bar (14.5 psi) ± 10%).
- Wait until the measuring value is stable, and then perform automatic gain calibration.
- Remove calibration adapter carefully by turning lightly.

Check the sensor for correct mounting!

By limiting the gain factor, calibration will not be possible any more when the sensitivity of the sensor reaches a residual sensitivity of 30 %. In this case the sensor has to be replaced.

Further information can be taken from the user manual of the GCD-05 Configuration and Calibration Software.

4.5 Addressing, only for GCD-05_Bus mode

In the GCD-05_Bus mode each transmitter gets its communication address.

In the standard version with the communication connector X12, addressing is done by means of the GCD-05 Service Tool or by the GCD-05 Configuration and Calibration Software.

See user manual of the Service Tool or of the Configuration and Calibration Software.

In the manual addressing version which can be identified by the address switch being equipped, there is a maximum of 60 addresses to be selected. See fig. 3.

The jumper is responsible to define the address group and the switch to define the address according to the following table.

Switch position	Jumper pos. 01 = address	Jumper pos. 02 = address	Jumper pos. 03 = address	Jumper pos. 04 = address
0	inactive	inactive	inactive	inactive
1	01	16	31	46
2	02	17	32	47
3	03	18	33	48
4	04	19	34	49
5	05	20	35	50
6	06	21	36	51
7	07	22	37	52
8	08	23	38	53
9	09	24	39	54
A	10	25	40	55
B	11	26	41	56
C	12	27	42	57
D	13	28	43	58
E	14	29	44	59
F	15	30	45	60

4.6 Option Relay Output

The two relays are activated in dependence of the gas concentration.

If the gas concentration exceeds the adjusted alarm threshold, the corresponding relay switches on.

If the gas concentration falls below the threshold minus hysteresis, the relay switches off again.

The contact function for relay 2, NC (normally closed) or NO (normally open), can be selected via the jumper NO/NC.

See fig 1 and 3. Relay 1 is equipped with a change-over contact.

Via the ModBus interface the two alarm thresholds and the hysteresis are freely adjustable at the PC within the measuring range.

The procedure can be read from the user manual "ModBus Software".

The following parameters are factory-set.

Alarm threshold 1 = Relay 1: 5 ppm

Alarm threshold 2 = Relay 2: 8 ppm

Switching hysteresis: 1 ppm

5 Inspection and Service

5.1 Inspections

Inspection, service and calibration of the transmitters should be done by trained technicians and executed at regular intervals.

We therefore recommend concluding a service contract with AP or one of their authorized partners.

5.2 Calibration

(See section 5.1 and 5.2)

- At commissioning and at periodic intervals determined by the person responsible for the gas detection system (recommendation every 6 months).
- After exchange of the sensor
- If in case of operational or climatic influences the sensitivity of the sensor falls below 30 % in operation, calibration will not be possible any more.

In this case the sensor has to be changed.

5.3 Exchange of Sensor Element

Consider static electricity! See point 3.

Sensor should always be installed without power applied:

- Unplug basic PCB AT03 carefully from the bottom part.
- Unplug old sensor element from the PCB.
- Take the new sensor out of the original packing.
- Plug the sensor element in the PCB at X7.
- Replug the PCB AT03 in the terminal blocks X4, X5 carefully.
- Calibrate according to section 5.

6 Troubleshooting

6.1 Analog Mode

Trouble	Cause	Solution
Output signal < 3 mA / 1,5 V and/or control voltage < 30 mV only for starting signal 2V/4 mA	Jumper 0-20 % not set	Check jumper position
	Power voltage not applied	Measure tension at X4: Two-wire: Pin 1 (+) and 4 (-) Three-wire: Pin 1 (+) and 2 (-)
	PCB AT03 not plugged in correctly at X4 and X5	Replug PCB correctly
	Wire break	Check the wiring
Output signal > 22 mA / 220 mV	Short-circuit	Check the wiring
Control voltage does not reach the calculated value	Sensor element not calibrated	Calibrate sensor element
	Sensor sensitivity < 30 %	Replace sensor element
No reaction of the output signal in spite of gas concentration	Power voltage not applied	Measure tension at X4
	Signal (Pin 4) not wired correctly	Check the wiring

6.2 GCD-05_Bus Mode

Trouble	Cause	Solution
Yellow LED not shining	Power voltage not applied	Measure tension at X4: Pin 1 (+) and 2 (-)
	PCB not plugged in correctly at X4/X5	Replug PCB correctly
	Wire break	Check wiring
Yellow LED not flashing	No communication at the transmitter	Transmitter not addressed, check bus wiring incl. topology and termination Voltage < 16 V
No control voltage at calibration	Jumper V-A not set	Set the jumper. Remove it after calibration!

7 Cross-sensitivity Data

The cross sensitivity can be read from the table Technical Data.

The table doesn't claim to be complete.

Other gases can have an influence on the sensitivity, too.

The indicated sensitivity data are only standard values referring to new sensor elements.

8 Technical Data

General sensor performances		
Gas type	Ozone (O ₃)	
Sensor element	Electrochemical, diffusion	
Measuring range	0 - 10 ppm (factory set) adjustable from 0 – 5 ppm to 1 – 10 ppm	
Temperature range	- 10 °C to + 45 °C (14 °F to 113 °F)	
Pressure range	Atmosphere ± 15 %	
Humidity	15 – 95 % RH non condensing	
Storage temperature range	5 °C to 30 °C (41 °F to 86 °F)	
Storage time	Max. 6 months	
Mounting height	0.3m (1 ft.)	
Stability & resolution	± 0,1 ppm	
Repeatability	± 5 % of reading	
Long-term output drift	< 2% signal loss/year	
Response time	t ₉₀ < 60 sec.	
Life expectancy	> 2 years/normal operating environment	
Cross sensitivity ¹	Concentration (ppm)	Reaction (ppm O ₃)
Chlorine, Cl ₂	5	~v 4
Ethylene, C ₂ H ₄	100	0
Carbon monoxide, CO	200	0
Hydrogen, H ₂	200	0
Nitrogen dioxide, NO ₂	5	~ 5
Nitrogen monoxide, NO	35	0
Sulphur dioxide, SO ₂	5	0
Electrical		
Power supply	18 - 28 VDC/AC, reverse polarity protected (2-wire mode only VDC)	
Power consumption (without options)	22 mA, max. (0,6 VA) - Analog mode 12 mA, max. (0,3 VA) - DGC-05 Bus mode	
Output signal		
Analog output signal	(0) 4 – 20 mA, load ≤ 500 Ω, Selectable: Current / tension (0) 2 - 10 V; load ≥ 50 k Ω Starting point 0 / 20 % proportional, overload and short-circuit proof	
Serial interface		
Transceiver	RS-485 / 19200 Baud (9600 ModBus)	
Protocol, depending on version	DGC-05 or ModBus	
Physical		
Enclosure plastic version type A ²	Polycarbonate	
Combustion behaviour ²	UI 94 V2	
Enclosure colour ²	RAL 7032 (light gray)	
Dimensions ² (H x W x D)	Approx. 94 x 130 x 57 mm (3.7 x 5.13 x 2.24 in.)	
Weight ²	Approx. 0.5 kg (1.1 lbs.)	
Protection class ²	IP 65	
Mounting ²	Wall mounting	
Cable entry	Standard 1 x M 20	
Wire connection	Screw-type terminal min. 0.25, max. 2.5 mm ² 24 to 14 AWG	
Wire distance	Current signal ca. 500 m (1500 ft.) Voltage signal ca. 200 m (600 ft.)	

¹ The table doesn't claim to be complete. Other gases, too, can have an influence on the sensitivity. The mentioned cross sensitivity data are only reference values valid for new sensors.

² Specifications only for standard enclosure, for further types see datasheet "AT-DT Enclosure".

Guidelines	EMC Directive 2004/108/EEC
	CE
Warranty	1 year on material (without sensor)
Options	
Relay output	
Alarm relay 1 (switching threshold 5 ppm)	30 VAC/DC 0,5 A, potential-free, SPDT
Alarm relay 2 (switching threshold 8 ppm)	30 VAC/DC 0,5 A, potential-free SPNO/SPNC
Power consumption	30 mA, (max. 0,8 VA)
Warning buzzer	
Acoustic pressure	85 dB (distance 300 mm) (1 ft.)
Frequency	3,5 kHz
Power consumption	30 mA, (max. 0,8 VA)
LCD display	
LCD	Two lines, 16 characters each, not illuminated
Power consumption	10 mA, (max. 0,3 VA)
Heating	
Temperature controlled	3 °C ±2°C (37.5 °F ± 3.6 °F)
Ambient temperature	- 30 °C (-22°F)
Power supply	18 - 28 VDC/AC
Power consumption	0,3 A; 7,5 VA
Analog input	
Only for RS-485 mode	4 – 20 mA overload and short-circuit proof, input resistance 200 Ω
Power supply for external transmitter	24 VDC max. 50 mA

9 Figures

Application: Analog mode
Fig. 1

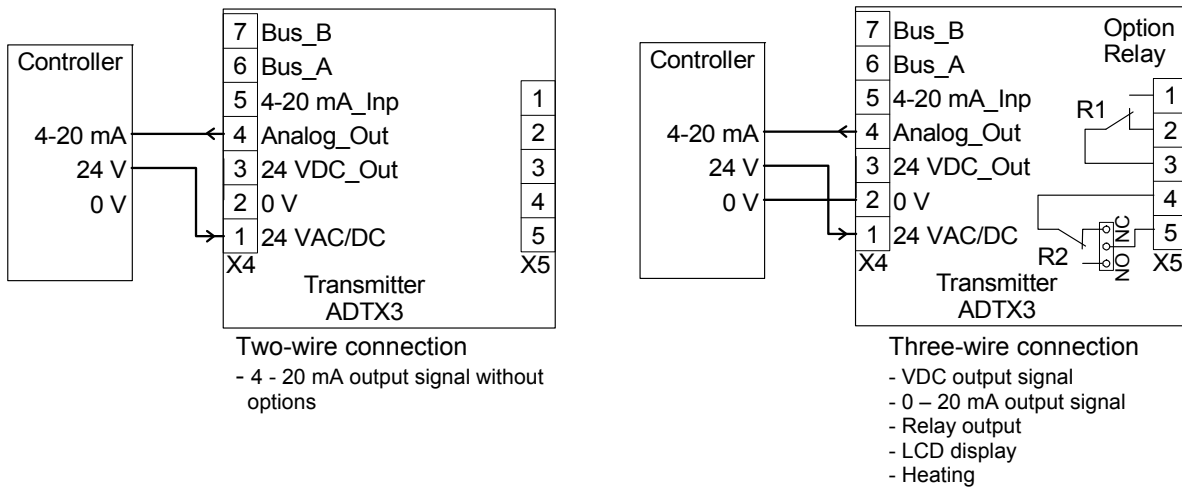

Application: GCD-05_Bus mode
Fig. 2

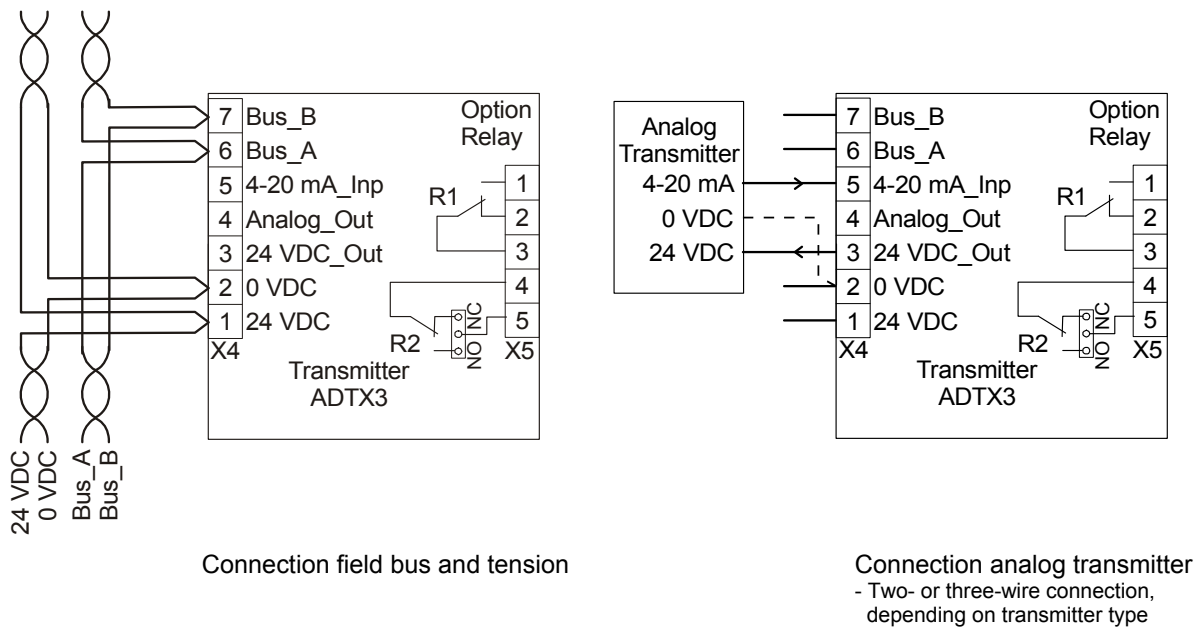

PCB AT03
Fig. 3

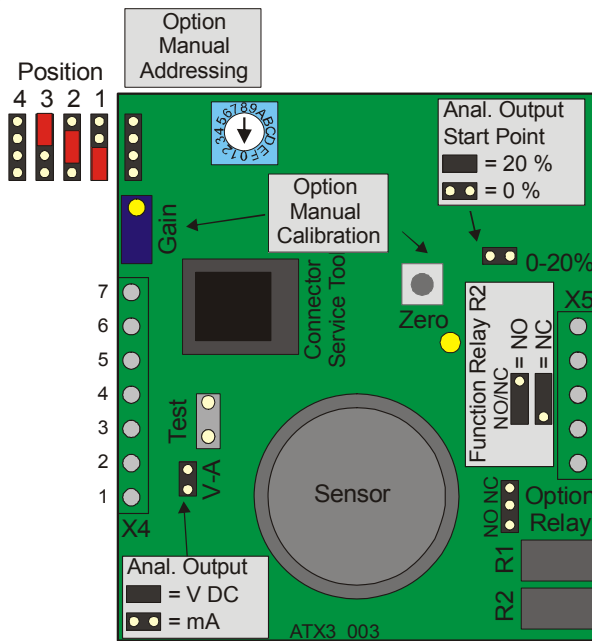

Terminal block

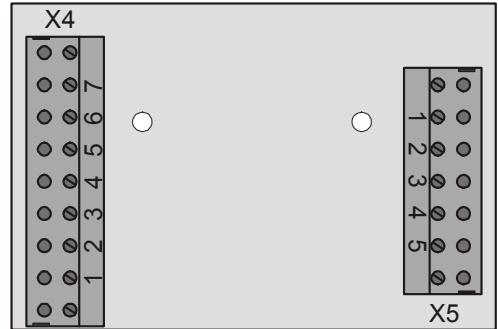

Selection analog output signal
Fig. 4

Jumper 0- 20 %	Jumper V-A	Output signal
Not set	Not set	0 – 20 mA
Set	Not set	4 – 20 mA
Not set	Set	0 – 10 V
Set	Set	2 – 10 V

Calibration adapter
Fig. 5
Type: Calibr-set



10 Notes and General Information

It is important to read this user manual thoroughly and clearly in order to understand the information and instructions.

The transmitters must be used within product specification capabilities.

The appropriate operating and maintenance instructions and recommendations must be followed.

Due to on-going product development,

AP reserves the right to change specifications without notice.

The information contained herein is based upon data considered to be accurate.

However, no guarantee is expressed or implied regarding the accuracy of this data.

10.1 Intended Product Application

The transmitters are designed and manufactured for control applications and air quality compliance in commercial buildings and manufacturing plants.

10.2 Installers' Responsibilities

It is the installer's responsibility to ensure that all transmitters are installed in compliance with all national and local codes and OSHA requirements.

Installation should be implemented only by technicians familiar with proper installation techniques and with codes, standards and proper safety procedures for control installations and the latest edition of the National Electrical Code (ANSI/NFPA70).

It is also essential to follow strictly all instructions as provided in the user manual.

10.3 Maintenance

It is recommended to check the transmitter regularly.

Due to regular maintenance any performance deviations may easily be corrected.

Re-calibration and part replacement in the field may be implemented by a qualified technician and with the appropriate tools.

Alternatively, the easily removable plug-in transmitter card with the sensor may be returned for service to Automatikprodukter.

10.4 Limited Warranty

Automatikprodukter warrants the transmitters for a period of one (1) year from the date of shipment against defects in material or workmanship.

Should any evidence of defects in material or workmanship occur during the warranty period, Automatikprodukter will repair or replace the product at their own discretion, without charge.

This warranty does not apply to units that have been altered, had attempted repair, or been subject to abuse, accidental or otherwise.

The warranty also does not apply to units in which the sensor element has been overexposed or gas poisoned.

The above warranty is in lieu of all other express warranties, obligations or liabilities.

This warranty applies only to the transmitter.

Automatikprodukter shall not be liable for any incidental or consequential damages arising out of or related to the use of the transmitters.