



UIHT 142

Features

- Combines 4 preset temperature ranges
- Choice of outputs and ranges on one unit
- Temperature range selectable via jumper setting
- Customised output scaling
- 3-wire connections
- Flange plate for adjust of penetration depth as option

Application

The immersion temperature transmitter UIHT 142 is used to sense temperature in HVAC systems and are intended for direct interfacing to any Energy Management System, such as boiler, flues and on medium/high temperature hot water systems up to +400°C

Can also be used in Flue Gas applications

Technical Data

Selectable output type	0-10Vdc or 4-20mA
Select. output range	-10 to + 40°C -10 to +110°C -10 to +160°C 0 to +400°C Custom, in range of -40 to 400°C
Supply Voltage	
0-10Vdc	24Vac +/-15%@50Hz or 24Vdc +15%-6%
4-20mA	24Vdc +/-15% -6%
Accuracy	±0,2°C
Sensor type	Pt100a
Connectors	Terminals for 0,5-2,5mm ² cable
Ambient range temp.	-10...+60°C
Ambient range hum.	0-80%RH, non-condensing
Housing	
Material	ABS (flame retardant)
Dimension	85x85x30
Protection Class	IP65

These products meet the demand of CE approval

Note

Current versions are NOT loop powered and will require a common 0V connection

Function

The sensing element is a PT100a.

The element change its resistance proportional to temperature and the electronics convert this resistance change to 4-20mA or 0-10Vdc

Design Features

The UIHT 142 sensing element is fitted into a 150/250mm long stainless steel probe fitted to an alu,inoium head.

The IP65 rated enclosure has fixing lugs for direct duct mounting.

The circuit board with electronics for 4-20mA or 0-10Vdc signal and connection terminals is mounted in the housing.

This is connected by a 1000mm cable to a plant sensor housing, where terminations and is located.

Ordering Codes

UIHT 142/15	150mm , 0-10Vdc/4-20mA selectable output, -10/+40°C, -10/+110°C, -10/+160°C, 0/+400°C
UIHT 142/25	250mm , 0-10Vdc/4-20mA selectable output, -10/+40°C, -10/+110°C, -10/+160°C, 0/+400°C
UDT 142X/15	150mm , 0-10Vdc/4-20mA selectable output, (custom temperature scaling)
UDT 142X/25	250mm , 0-10Vdc/4-20mA selectable output, (custom temperature scaling)

Calibration to customer specification in the range -40...+400°C (dependent on sensor type and application)

TDDFP Duct flange plate for adjust length of probe

Temperature Calibration Service available

Mounting

It is recommended that the unit be mounted with the cable entry at the bottom.

If the cable is fed from above then into the cable gland at the bottom, it is recommended that a rain loop be placed in the cable before entry into the transmitter.

Remove the front cover by twisting the lid and separating from the main body.

Using the base of the housing as a template mark the hole centres.

Drill two pilot holes at 85 mm centres in the surface on which the sensor is to be mounted, and fix the transmitter with appropriate screws.

The housing is designed to make it easy for an electric screwdriver to be used if desired.

Feed the cable through the waterproof gland and terminate the cores at the terminal block.

Leaving some slack inside the unit, tighten the cable gland onto the cable to ensure watertightness.

Replace the lid after the electrical connections have been made.

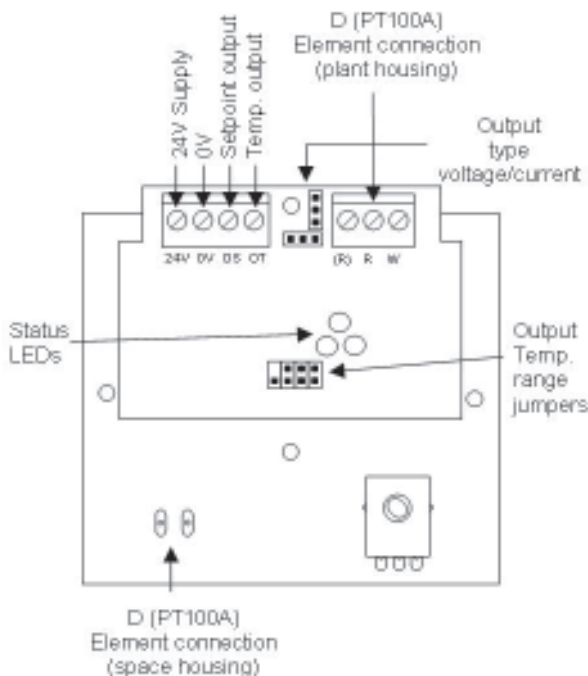

Current output

If using a current output, the sensor must only be used with a 24Vdc supply.

The sensor may be damaged if supplied with AC

Jumper Settings

Output Temperature Range Selection

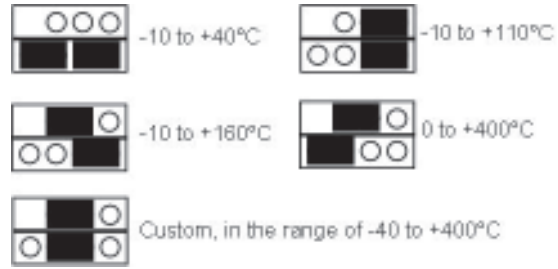

Note: If the range links are incorrectly set, the output range will default to -10/+40°C

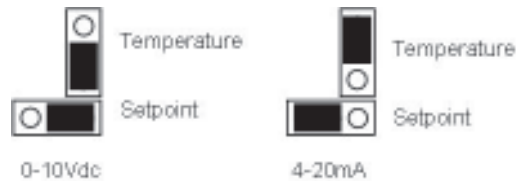

Note: There is one link for SP and one for T, which can be set independently from each other, allowing (for example) the temperature output as 0-10Vdc and setpoint option output as 4-20mA. Setpoint is not available of UIHT.

LED Status

Normal:

The green LED indicates the supply condition. If the power supply is normal the green LED is ON continuously. This shows that the UDT is powered correctly.

Low Supply Voltage:

If power supply falls below about 22V the green LED does double flashes twice a second.

*_*_*_*_*_*_*_*_*_*_*_*_*_*_*_**

The PCB tries to maintain the correct output but may be unable to achieve the specified voltage or current level. At very low voltages it will stop working.

High Supply Voltage:

If the power supply is above 40V the green LED flashes 6 times a second:

*_*_*_*_*_*_*_*_*_*_*_*_*_*_*_**

The PCB tries to maintain the correct outputs but components on the PCB may overheat causing unreliability and ultimately failure.

4-20mA output:

The red LED is on when the PCB is in 4-20mA mode and working correctly. For this to be so these conditions must be met:

1. The output select jumper(s) must be set to the 4-20mA position.
2. The output load must be an impedance of 500Ω or less.
3. The PCB is capable of sourcing the correct output current. (The red LED may flash if the PSU is below 22V or the impedance is more than 500Ω).
4. If using a current output mode, the sensor must only be used with a 24V DC supply. The sensor may be damaged if supplied with AC.

0-10Vdc output:

The output select jumper(s) must be connected in the 0-10Vdc position, minimum impedance 2kΩ.