



Features

- Digital measurement value processing incl. temperature compensation
- Internal functional control with integrated Hardware Watchdog
- Data / measured values in μC Sensor, therefore simple exchange of sensor uncalibrated <-> calibrated
- Software according to SIL2 compliant development process
- Modular technology (plug-in and replaceable)
- Easy maintenance and calibration by exchange of the sensor cartridge or by comfortable on-site calibration
- Serial RS 485 interface with protocol for CGD06 Modbus and BacNet.
- IP 65 version

Technical Data	Basic unit
Power supply	16 – 29 Vdc, reverse-polarity protected
Power consumption	10 mA (0.24 VA), 24Vdc
Output for GCD bus	5 Vdc, 250 mA max. Overload, short-circuit and reverse-polarity protected
Temperature range	-20 °C to +50 °C
Humidity range	15 - 90 % r.H non-condensing
Storage temperature	5 °C to 30 °C (41 °F to 86 °F)
GCD bus interface	1-wire / 19200 Baud
Field bus interface	RS 485 / 19200 Baud
Tool bus interface	2-wire / 19200 Baud
Mounting Height	0.2 m above floor
Field bus	Screw-type terminal min. 0.25 mm ² , max. 2.5 mm ²
Local bus for sensor	3-pin connector
Directives	EMC directives 2004/108/EC CE Conformity to: EN 50271 EN 61010-1:2010 ANSI/UL 61010-1 CAN/CSA-C22.2 No. 61010-1
Housing	90 x 130 x 57 mm

Application

The Fieldbus Detector is used for integration in bus network.

Design Features

The detector provides the power supply of the sensors and makes the measured data available for digital communication.

Communication with the CGD06 controller takes place via the RS 485 fieldbus interface with CGD06 protocol.

Other communication protocols as Modbus and BacNet for direct connection to superordinate BMS are available.

The sensor is connected to the local bus via a plug connection enabling simple exchange instead of an on-site calibration.

The internal X-Change routine recognizes the exchanging process and the exchanged sensor and starts the measurement mode automatically.

An LED indicates the correct procedure of the exchange operation.

As an alternative, the on-site calibration via the CGD06 Service Tool can be performed with the integrated, comfortable calibration routine.

Ordering Codes

BNO2 010M	ModBus	0-10 ppm 16-29Vdc
BNO2 010B	BacNet	0-100ppm 16-29Vdc
BNO2 010C	CGD-bus	0-10 ppm 16-29Vdc
XNO2 0100	Sensor Head (Repl.)	0-10 ppm for exchange (2 years)

Cont'd on p. 2

Technical Data		Sensor		Ordering Codes, cont'd		
Electrical						
Power supply		5 Vdc from sensor board, reverse polarity protected		BNO2 030M	ModBus	0-30 ppm 16-29Vdc
Power consumption:		50 mA, max. (1.0 VA)		BNO2 030B	BacNet	0-30 ppm 16-29Vdc
Serial interface local bus		1-wire / 19200 Baud		BNO2 030C	CGD-bus	0-30 ppm 16-29Vdc
				XNO2 030	Sensor	0-30 ppm for exchange (2 years)
				(M, B, C) ¹	Head (Repl.)	
Sensor element		Electrochemical		BNO2 500M	ModBus	0-500 ppm 16-29Vdc
Measuring range		0 – 10, 0 - 30, 0 - 500 ppm		BNO2 500B	BacNet	0-500 ppm 16-29Vdc
Accuracy		± 0.5 ppm		BNO2 500C	CGD-bus	0-500 ppm 16-29Vdc
Resolution		0.1 ppm		XNO2 300	Sensor	0-500 ppm for exchange (2 years)
Repeatability		< ± 2 % sig.		(M, B, C) ¹	Head (Repl.)	
Response time t₉₀		≤25 sec.		BBUZ	Built-in buzzer	
Zero point variation		± 0.2ppm		BBUZ LED	Buzzer with built-in LED indication	
Zero Drift		< 2 % signal / month		BDOCT	Duct Kit	
Zero Gain		< 2 % signal / month		DR 24/30	Power supply 24Vdc	
Pressure range		Atmospheric ± 20 %		BSTAIN	Option, stainless housing	
Sensor life time		2 years / normal ambient conditions		REG	Pressure regulator, flow adjustment to 0.5 l/min	
Calibration interval¹		12 months		GAS	Calibration Gas 17 liters	
Storage temperature range		+ 5 to + 30 °C (41 to 86 °F)		GKIT	Calibration Kit	
Warranty		1 year on material (without sensor element)		Alarm Units		
				AAW 24	Warning Horn 24Vdc 98dB	
				AAW 230	Warning Horn 230Vac 98dB	
				OA 24	Flashlight 24Vdc, red	
				OAW 24	Combined Warning Horn/Flashlight, 24Vdc 98dB	
				OAW 230	Combined Warning Horn/Flashlight, 230Vac 98dB	
				OAW 24T	Combined Warning Horn/Flashlight with reset button, 24Vdc 98dB	
				Warning Plate		
				Gas Alarm	Flashing gas alarm plate "GASALARM" 24Vac/dc	
				SP 600	Impact Protection	

¹ Manufacturer-recommended calibration interval for normal environmental conditions.

Electrical connection

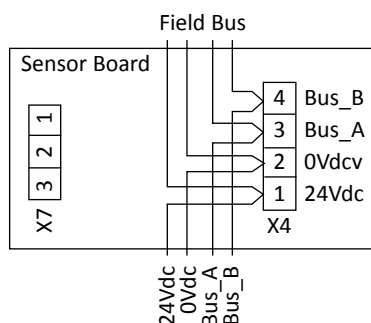

EU directives

Special protection for people and buildings. The units are manufactured in accordance with the rules and directives such as EN50545.

Products delivered by the AP meets and exceeds the requirements of the new European standard EN50545.

Safety functions control devices for connection warnings regarding functionality and open circuit - day and night. Level SIL2 according to EN 50271.

Gas monitoring and ventilation control in parking areas

Gas monitoring in parking areas meets two main needs:

- To give a warning when the amount of harmful gases reaches an unhealthy level.
- To ensure that the ventilation control is done in the best and most profitable way, ie for fresh air needs.

Hazardous gases

Petrol and diesel exhaust fumes emit harmful levels of nitrogen dioxides (NO₂), hydrocarbons (CH) and carbon monoxides (CO).

As a rule only carbon monoxides and nitrogen dioxides are monitored in parking areas since it is often (wrongly) believed that other gases do not reach harmful levels.

Carbon monoxide is a highly dangerous toxic gas (see table at the top of page 5).

Nitrogen dioxide is a carcinogen.

When considering monoxide from gas monitoring perspective it is appropriate to have two alarm levels, where one level, occurs at about 20 ppm, and the other at about 35 ppm.

A gas alert sign or similar can warn of unhealthy carbon monoxide levels at the lower alert level. At the higher alert level, ie critical alarm level, it may be appropriate to allow the system to activate a warning siren.

A detector density of at least 1 detector/400 m² is would be appropriate.

In case there are diesel vehicles in the parking area, it is important to take other harmful gases into consideration, such as nitrogen oxides and hydrocarbons.

In cases described above, specific monoxide detectors cannot cover the detection needs. Detectors that can detect these gases are required, eg, the GNO₂ gas detector.

Application areas

- Car repair shops
- Trucks/Indoor
- Parking areas
- Tunnels
- Mines
- Ice Hockey Rinks
- Bus/Lorry Terminals
- Generator rooms
- Garages

Ventilation control

The minimum requirement to be set in ventilation control is to make certain that the gas monitoring facility affects the ventilation in such a way that if harmful gas concentrations occur, the fresh air intakes must increase in order to reduce gas concentrations to reach harmless levels.

A well-regulated demand controlled ventilation in a parking area not only improves the air quality but it also minimizes the energy consumption by avoiding unnecessary ventilation.

Optimal ventilation with regard to gas concentrations can usually be

achieved by regular ventilation.

In a modern gas monitoring facility there are functions both for alarms (two levels) and controls for air evacuation.

The control options in the gas monitoring facility can be adapted to the control modes of most ventilation facilities.

The gas monitoring facility allows for incrementally controlled ventilation.

Example:

At low load, ventilation is running at 1/2-power. If the gas concentration exceeds 20 ppm (level 1), the sensors react and ventilation is controlled is switched over to the 1/1 power.

Staff Alarm - e.g. warning by sirens in the parking area - is given when the concentration exceeds 35 ppm (level 2).

Stepless control via frequency converter controller or via DDC/PLC gives the best energy savings.

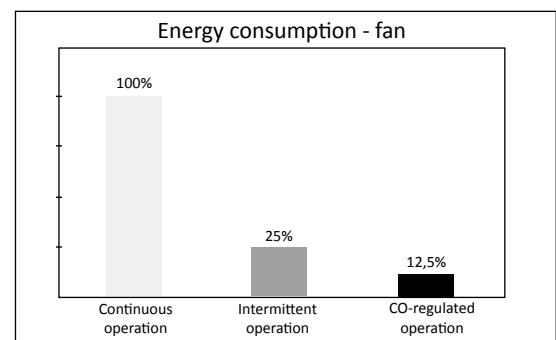

By monitoring CO levels and only running the fans when necessary the CO detector becomes a significant energy saver.

Normally parking area ventilation need only be operational in 2 out of 24 hours, which naturally saves a great deal of energy.

Poisoning Hazard

There are several gas that when released in the air uncontrolled can poison and kill people. Common poisonous gases in industry are e.g. ammonia, carbon monoxide and hydrogen sulphide (all the examples listed are also flammable).

Experts within occupational health and medicine estimate the gas concentrations for harmful gases when the adverse impacts are minor.

In Sweden, these so called hygienic levels are set and updated by the Swedish Work Environment Authority.

A distinction is made between the maximum exposure limit, i.e. the maximum value for a 15-minute average exposure, and the exposure limit value, i.e. the maximum value for an 8-hour average exposure.

When monitoring gas it is advisable to let the hygienic exposure limit values provide indications for the choice of alarm levels.

This does not mean however that you necessarily need to adhere to the above described levels.

Alarm levels should be chosen according to how dangerous the gas is and the particular installation conditions.

How carbon monoxide affects people			
Vol-%	ppm	Contact duration	Symptom med möjliga följder
0.02	200	2-3 h	Light headache
0.04	400	1-2 h	Severe headache (forehead)
0.08	800	45 min 2 h	Malfunctions in the body Unconsciousness
0.16	1600	20 min 2 h	Malfunctions in the body Death
0.32	3200	5-10 min 30 min	Malfunctions in the body Death
0.64	6400	1-2 min 10-15 min	Malfunctions in the body Death
1.28	12800	1-3 min	Death

Emission values for different engine types, as well as hygienic exposure limits of the gases									
GAS	Impurities (g/kg fuel) caused by petrol and diesel engines			ppm content petrol exhausts	ppm content diesel exhausts	Hygienic limits			
						ppm 8 h	mg/m ³ 8 h	ppm 15 min	mg/m ³ 15 min
NO ₂	25	10,5	42	100-200	2000	25	30	-	-
CO	155	12	13	20000-60000	1000	35	39	50	55
CH	15	6	4	200-1500	500	25-1000			

By using gas detectors with an analog output, 4-20 mA, which sends the signal to a computerized control, regulation and monitoring system, the ventilation control is done in a more refined manner.

Depending on the capacity of the computerized system, the ventilation can be controlled continuously instead of stepwise. One can have a throttle control, optional time delays, breakdown of the ventilation into zones, etc.

The impact of various gases and vapours on people and hygienic exposure limits. Gas concentration in ppm (parts per million).					
Gas	Lethal dose 5-10 min duration	Severe poisoning	Temporary trouble	Max exp. lim.	Av. exp. lim.
Ammonia (NH ₃)	5.000	2.500	250	50	25
Carbon monoxide (CO)	7.000	2.000	1.000	100	35
Petrol	20.000	7.500	3.000	-	200*
Acetylene	500.000	250.000	100.000	-	-

* Refers to mg/m³

Installation exemple

Installation in parking area with mechanical ventilation at 40 x 40 m (1600m²).

The CO-detectors are placed at 140-180 cm above the floor, evenly distributed over the area, with consideration taken for walls and section dividers.

As a rule of thumb there should be one detector per 400m², the exact number depending on the shape of the area.

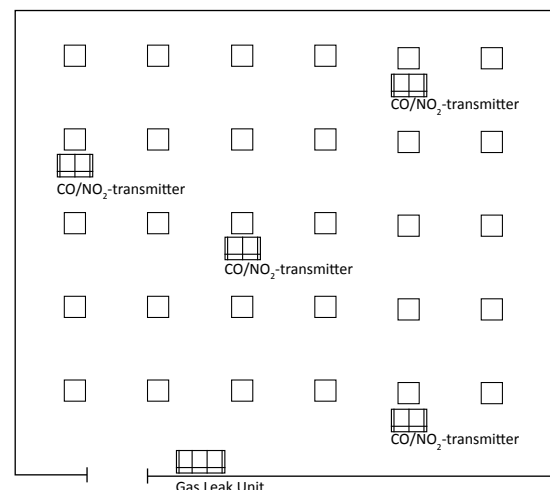

We cannot be held responsible for errors in the manual/datasheet and reserve the right to correct any errors and to make product improvements, which may affect the accuracy of the manual/datasheet, without prior notice.