

USERS' MANUAL AND INSTALLATION GUIDE



R R
0 0
3 1
5 5



Nature System®



A.F.C. System®



INDEX

1	GENERAL	5
1.1	IDENTIFICATION OF THE MACHINE	5
1.2	MARKING OF THE MACHINE	6
1.3	PARTS TO ADJUST.....	6
1.3.1	<i>How to open the door</i>	6
2	PACKAGING AND TRANSPORT	8
2.1	PACKAGING	8
2.2	TRANSPORT	8
3	INSTALLATION	9
3.1	INSTALLATION OF THE PLINTH	9
3.2	HOW TO MOVE THE MACHINE.....	9
3.3	OPTIMUM POSITION	10
3.4	OVERALL DIMENSIONS	11
3.5	VENTILATING THE PREMISES	11
3.6	FILTER UNIT.....	11
3.6.1	<i>METAL PRE-FILTER</i>	12
3.7	ELECTROSTATIC CELL.....	12
3.7.1	<i>ionisation wires</i>	13
3.7.2	<i>collection blades</i>	13
3.7.3	<i>insulators</i>	13
3.7.4	<i>contact terminal strip</i>	13
4	SAFETY DEVICES	14
4.1	MECHANICAL SAFETY DEVICES.....	14
4.2	ELECTRICAL SAFETY DEVICES	14
4.2.1	<i>Electronic circuit protection devices</i>	14
4.3	FUSE	15
5	MAINTENANCE OF THE MACHINE	16
5.1	REPLACEMENT OF THE ION-EMITTER NEEDLES	16
6	ORDINARY MAINTENANCE	17
6.1	FILTER MAINTENANCE.....	17
6.1.1	<i>Access Door</i>	17
6.1.2	<i>Washing the filters</i>	18
6.2	GENERAL INSPECTION OF THE FILTERS.....	19
6.3	CLEANING THE MACHINE	19
6.4	REPLACEMENT OF THE PRE-FILTER ON THE GRID	19
7	AVAILABLE VERSIONS	20
8	NATURE SYSTEM ®	22
8.1	CONTROL PANEL.....	23
8.1.1	<i>DISPLAY</i>	23
8.1.2	<i>RECEIVER</i>	23
8.1.3	<i>MANUAL, TEST, ON-OFF FILTER AND RESET BUTTONS</i>	24
8.1.4	<i>OPERATION OF THE MACHINE</i>	24
8.1.5	<i>FILTERING STATUS</i>	25
8.2	INFRARED REMOTE CONTROL UNIT.....	25
8.3	POWER SUPPLY AND ANTI BLACK-OUT SYSTEM.....	25
8.4	ENVIRONMENTAL REVITALISATION (RIVITALIZZAZIONE AMBIENTALE®)	26
8.5	PURIFICATION.....	26
8.6	NORMAL CONDITIONS OF OPERATION	26
8.7	NIGHT-TIME REVITALISATION WITH ENVIRONMENTAL DEODORIZATION.....	27
8.8	SIGNALS.....	27
8.9	STATE OF FILTRATION EFFICIENCY.....	27

8.10	OPTIMAL APPLICATION OF THE REVITALIZER.....	28
8.11	ELECTRONIC CIRCUIT ALARM SIGNALS.....	29
8.12	ELECTRONIC CIRCUIT ANOMALOUS SIGNALS	30
9	AFC SYSTEM®	31
9.1	CONTROL PANEL	32
9.1.1	DISPLAY.....	32
9.1.2	(RECEIVER).....	32
9.1.3	MANUAL, TEST, ON-OFF FILTER AND RESET BUTTONS	33
9.2	OPERATION OF THE MACHINE.....	33
9.3	FILTERING STATUS	34
9.4	INFRARED REMOTE CONTROL UNIT.....	34
9.5	POWER SUPPLY AND ANTI BLACK-OUT SYSTEM.....	34
9.6	PURIFICATION.....	35
9.7	SIGNALS.....	35
9.8	STATE OF FILTRATION EFFICIENCY.....	35
9.9	ELECTRONIC CIRCUIT ALARM SIGNALS.....	36
9.10	ELECTRONIC CIRCUIT ANOMALOUS SIGNALS	37
10	TECHNICAL DATA	38
11	CERTIFICATIONS.....	38
11.1	CERTIFICATION C.N.R.....	38
11.2	CERTIFICATION OF COMPONENTS	38

1

GENERAL

Air cleaners and Revitalizers 170r, built for the purposes of improving the characteristics of the air in closed environments.

There are available two different technologies: Nature System, AFC System, Basic System.

1.1 IDENTIFICATION OF THE MACHINE

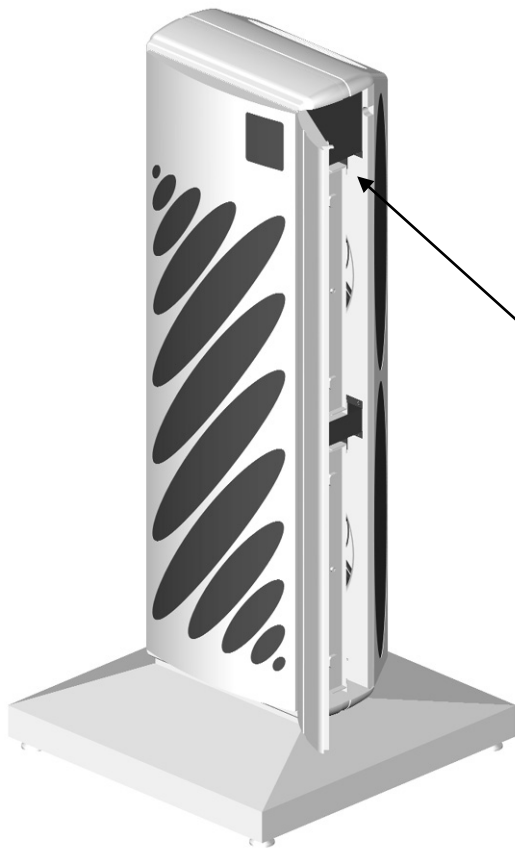

There is a plate in every machine showing the model and the series number which identify the machine.

This plate is located on the inside of the machine and it is therefore necessary to open the door of the machine itself to see it.

identification plate

The plate shows the technical data of operation and the sign of identification of the machine.

When you call for technical assistance, provide the data relative to the model of the machine, its type and series number.

MODEL	
TYPE	
SERIAL NUMBER	
KW POWER MAX	
HZ FREQUENCY RANGE	*****
AC VOLTAGE	*****
A CURRENT MAX	*****
FUSE	*****
<p>- PER UNA PROTEZIONE CONTINUA CONTRO I RISCHI D'INCENDIO USARE SOLO FUSIBILI DELLO STESSO TIPO E DELLA STESSA PORTATA</p> <p>- L'APPARECCHIATURA DEVE ESSERE COLLEGATA ALLA PRESA DI TERRA</p>	
<p>- PER UNA PROTEZIONE CONTINUA CONTRO I RISCHI D'INCENDIO USARE SOLO FUSIBILI DELLO STESSO TIPO E DELLA STESSA PORTATA</p> <p>- L'APPARECCHIATURA DEVE ESSERE COLLEGATA ALLA PRESA DI TERRA</p>	
<p>- PER UNA PROTEZIONE CONTINUA CONTRO I RISCHI D'INCENDIO USARE SOLO FUSIBILI DELLO STESSO TIPO E DELLA STESSA PORTATA</p> <p>- L'APPARECCHIATURA DEVE ESSERE COLLEGATA ALLA PRESA DI TERRA</p>	
<p>- PER UNA PROTEZIONE CONTINUA CONTRO I RISCHI D'INCENDIO USARE SOLO FUSIBILI DELLO STESSO TIPO E DELLA STESSA PORTATA</p> <p>- L'APPARECCHIATURA DEVE ESSERE COLLEGATA ALLA PRESA DI TERRA</p>	
<p>- PER UNA PROTEZIONE CONTINUA CONTRO I RISCHI D'INCENDIO USARE SOLO FUSIBILI DELLO STESSO TIPO E DELLA STESSA PORTATA</p> <p>- L'APPARECCHIATURA DEVE ESSERE COLLEGATA ALLA PRESA DI TERRA</p>	

Model

Type

N series number

1.2 MARKING OF THE MACHINE

The EC conformity mark is located on the control panel of the machine.

1.3 PARTS TO ADJUST

The operations which the user must be able to carry out are divided into those of ordinary management and those of maintenance. Ordinary management of the information takes place by means of the control panel which displays the operating status of the machine. The filters can be accessed to carry out maintenance by opening the door.

1.3.1 *How to open the door*

To open the door, it is necessary to introduce a finger in the specially slit provided.

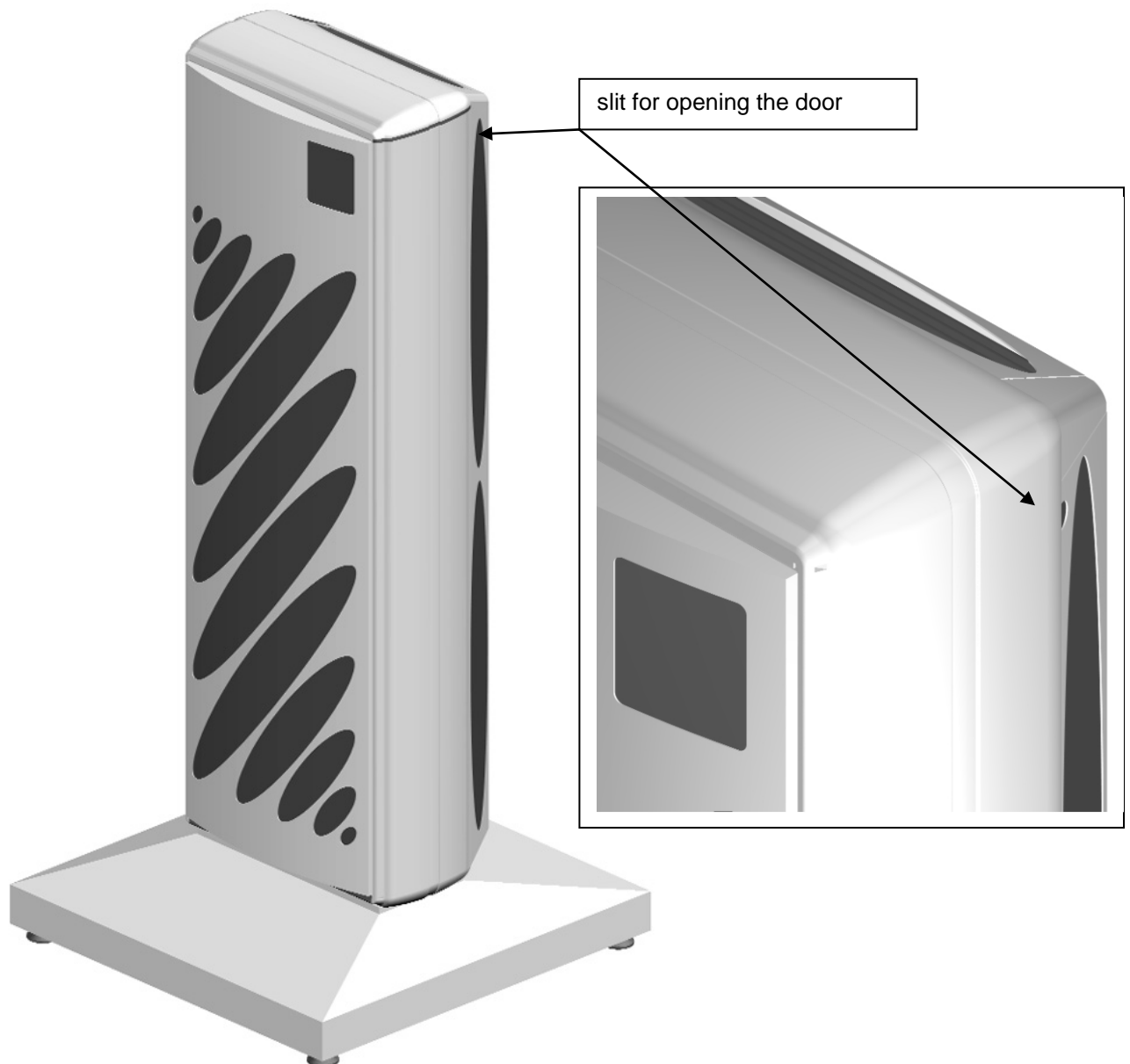



2

PACKAGING AND TRANSPORT

2.1 PACKAGING

The machine is supplied in a cardboard box internally lined with 6 pieces of polystyrene. We recommend keeping all the packaging just in case the machine has to be returned to the manufacturer or the dealer for extraordinary maintenance or repairs.

The following objects should be found in the box:

- the required machine
- bracket for supporting the machine (only if for ceiling installation)
- users' manual and guarantee leaflet
- remote control unit
- plug

2.2 TRANSPORT

To limit damage and consequent charges for unforeseen repair work, if the machine has to be sent to the manufacturer for overhaul or repair, the following procedure is recommended:

- pack the machine in the original carton; if this is not possible, you must pack the machine with polystyrene protection.
- ship to the manufacturer or to the local dealer.

3

INSTALLATION

3.1 INSTALLATION OF THE PLINTH

The machine is provided with a dismantled plinth, follow the instructions to install it:

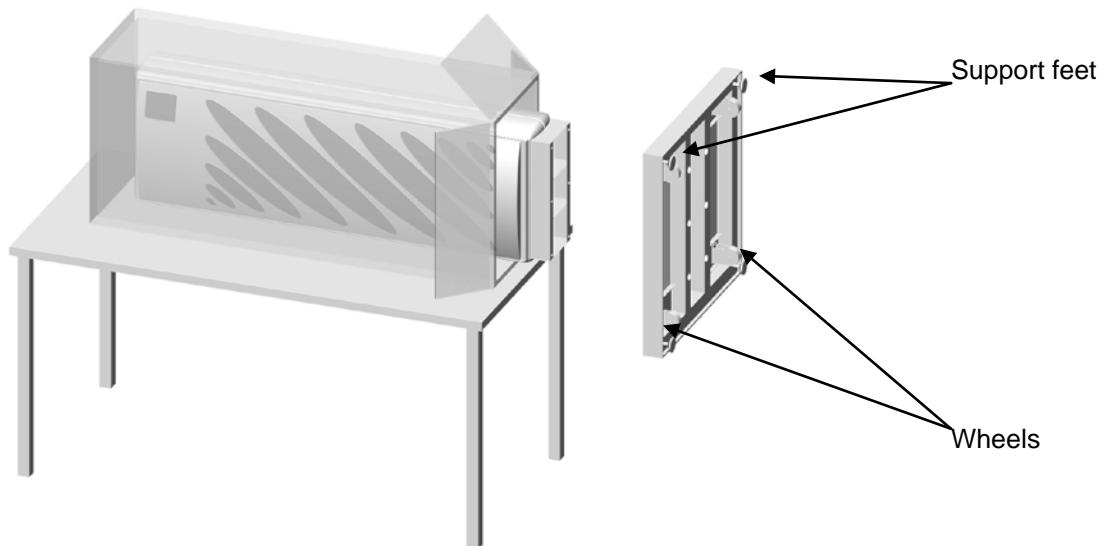

- lay the machine, still within its packaging, on a table or on a raised support
- open the box from the bottom and pull the machine out partly
- open the box of the plinth
- insert the plinth on the support fixed on the machine as shown in the figure
- fix the locking bolts with the tube-key provided
- make sure that the support feet are screwed and that only can the wheels touch the ground
- lift and place the machine on the ground (this needs to be done at least by two people)

3.2 HOW TO MOVE THE MACHINE

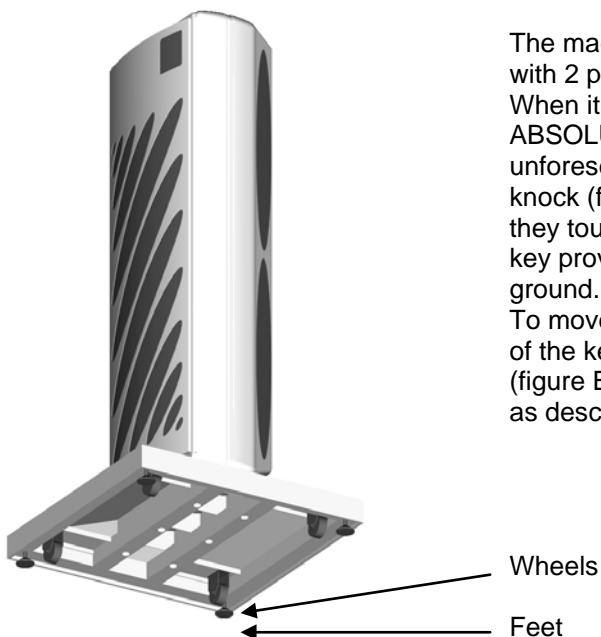

The machine is provided with 4 wheels to be moved and with 2 pairs of feet for when it is fixed.

When it is fixed, the feet of the machine **ABSOLUTELY** need to touch the ground to prevent any unforeseeable movements, as in the case of a casual knock (figure A). Therefore unscrew the feet (x4) until they touch the floor and complete the operation when the wheels are 5 mm above the ground.

To move the machine, screw the feet (x4) with the use of the key provided until the wheels touch the ground (figure B), then move the machine and fix it with the feet as described above.

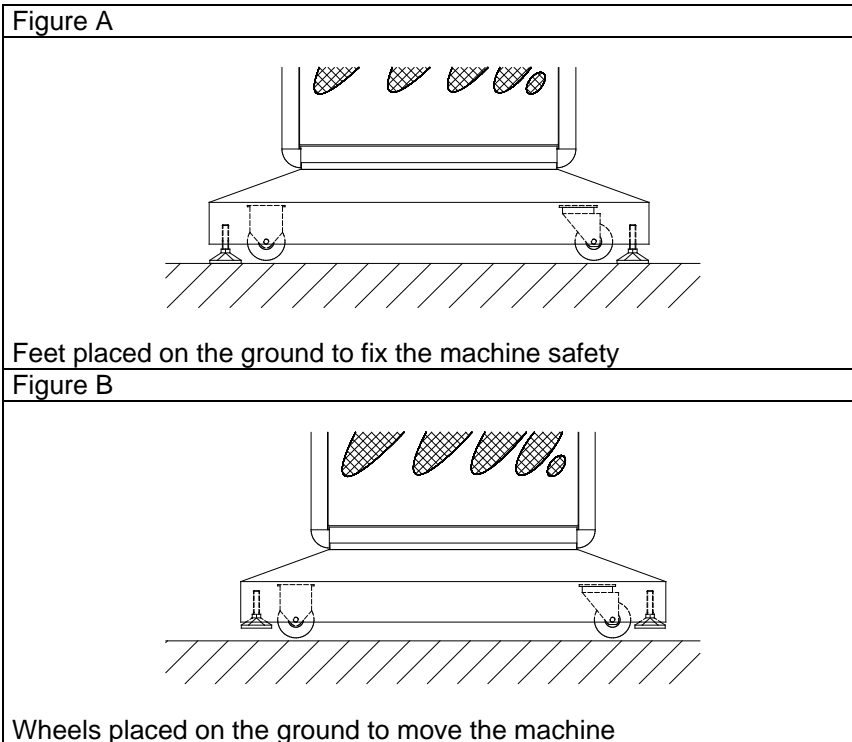

3.3 OPTIMUM POSITION

For correct running, place the machine to let the air perform the under-shown cycle. The air coming out from the back openings must not have any obstacles preventing the depuration cycle from being accomplished.

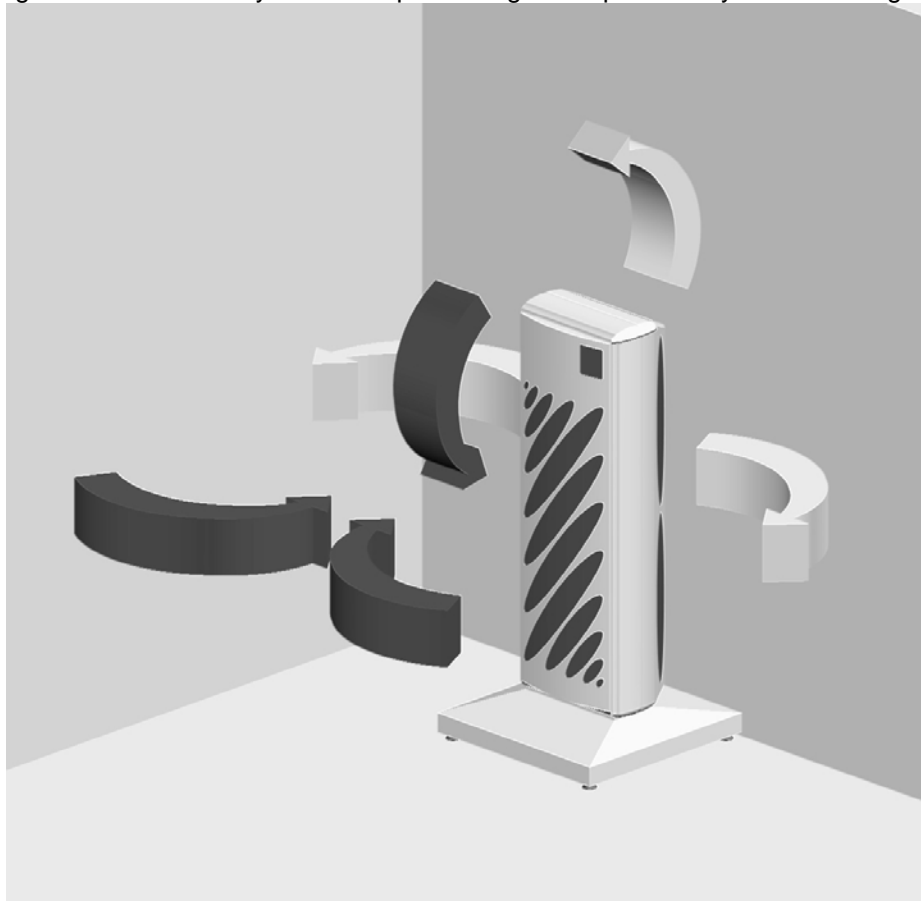

3.4 OVERALL DIMENSIONS

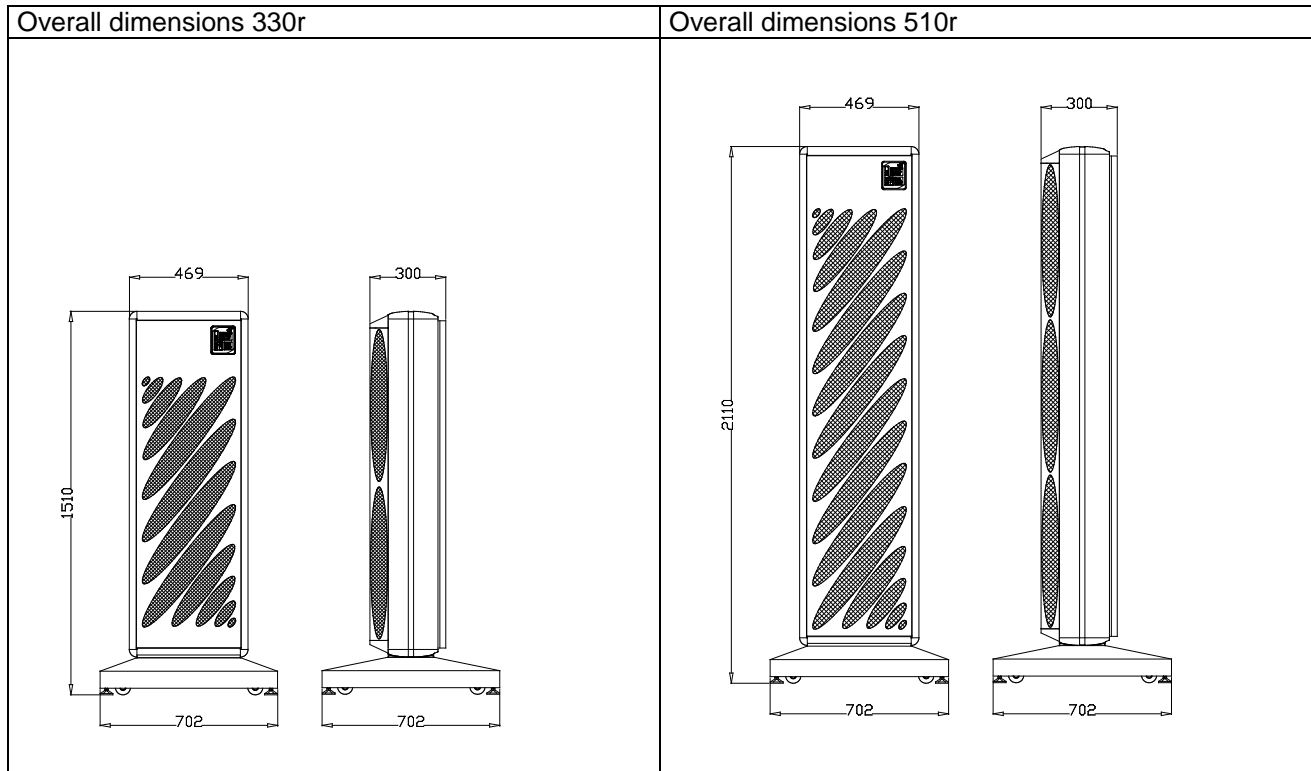

3.5 VENTILATING THE PREMISES

All rooms where people are present carrying out any activity must be fitted with appropriate apparatuses which guarantee adequate reoxygenation of the environment.

This reoxygenation is fundamental for the well-being of people and must be realised bearing in mind that every person needs at least 12.5m³ of air every hour where there is a high-efficiency air purification system.

It is therefore necessary to provide the premises with an air introduction system in proportion to the average number of people present in them.

To calculate the quantity of air in m³/h to introduce from the exterior, it is sufficient to multiply the average number of persons present by a coefficient of 12.5.

3.6 FILTER UNIT

There are two different filters in the machine:

- metal pre-filter 115/3-R
- electrostatic cell 115/3-R

	metal pre-filter 115/3R Codice A05500	electrostatic cell 115/3R Codice A00006
330r	2	2
510r	3	3

3.6.1 METAL PRE-FILTER

The metal pre-filter is for trapping the bigger particles present in the air and for distributing the flow uniformly.

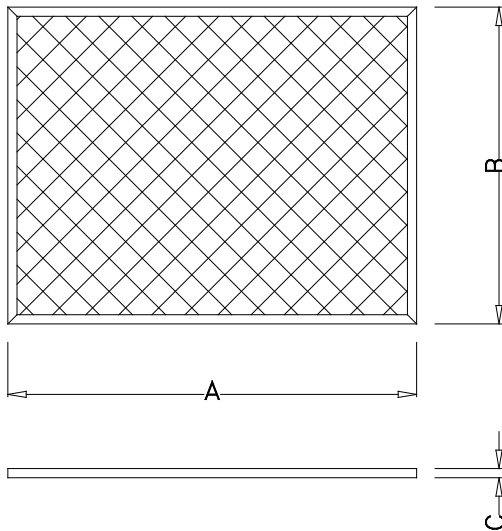

FILTER MODEL	DIMENSIONS		
	A	B	C
115/3-R	545	406	6

During operation, the metal pre-filter must always be inserted in its seat.
During maintenance, it must be handled with care to prevent deformation or damage

3.7 ELECTROSTATIC CELL

The electrostatic cell filters the pollutant particles with an efficiency of 99%.
Its dimensions vary depending on the model it is fitted in.

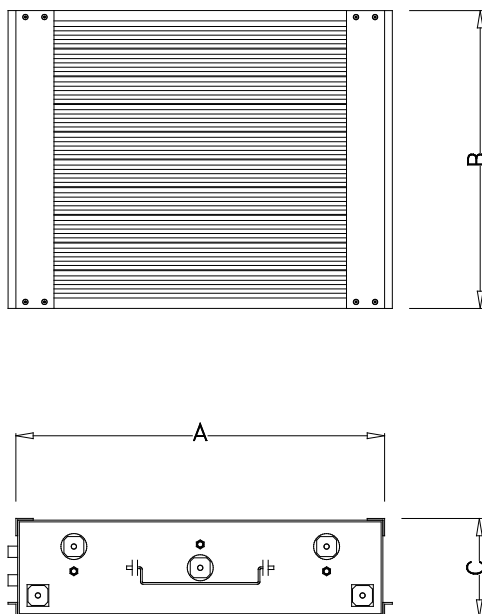

FILTER MODEL	DIMENSIONS		
	A	B	C
115/3-R	525	406	115

The cell is built entirely in anticorrosional aluminium. There are four distinct zones in the cell:

- A - ionisation wires
- B - collection blades
- C - insulators
- D - contact terminal strip

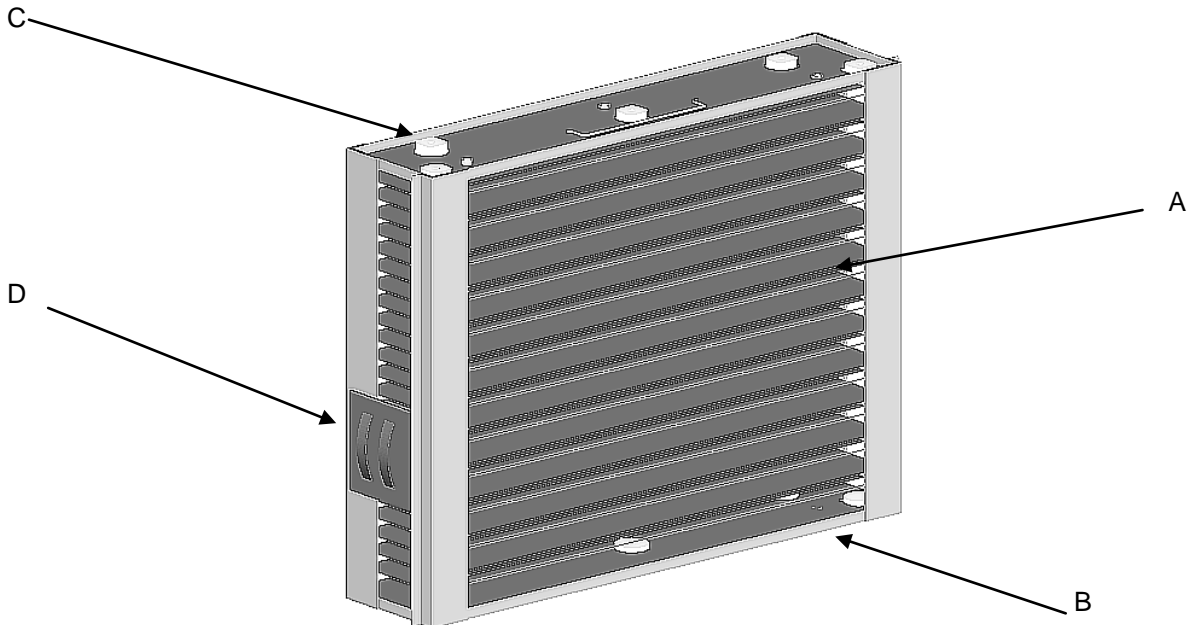

3.7.1 ionisation wires

The electrostatic cell has 12 ionising wires. These must be intact, clean and well-tensioned at all times. If one breaks, it is necessary to replace it. The technical service must be called in this case. The manufacturer will not guarantee the efficiency of the filter unit if non-original wires are inserted or wires which are not of the type recommended by the technical service.

3.7.2 collection blades

The function of the collection blades which make up the central body of the cell is to capture and hold the pollutant agents. Visually, the blades must be straight, without undulations and free from trapped foreign bodies.

3.7.3 insulators

The insulators are built in an extremely high quality ceramic material and their function is to electrically insulate the high-voltage parts of the electrostatic cell from the earthed parts. They must be dry and thoroughly clean after maintenance.

3.7.4 contact terminal strip

The terminal strip for the contacts is the point through which the electrical connection is made between the electronic circuit and the electrostatic cell. During maintenance, inspect to ensure that the flexible arches are intact. Also ensure that there are no burns or cracks on the terminal strip caused by the voltage.

4

S A F E T Y D E V I C E S

The machine is fitted with mechanical and electrical safety devices which must not be removed or altered for any reason.

4.1 MECHANICAL SAFETY DEVICES

The grill, where the air to be cleaned passes through, is designed to protect persons from accidental contact with the live parts. This grill can only be removed in the event of extraordinary maintenance or repair operations.

In all cases, before removing it, it is necessary to cut off the electrical power.

NEVER INSTALL OR START THE AIR PURIFIER WITHOUT THE PROTECTIVE GRILL.

There are air diffusion fins in the top of the machine. They have the double function of diffusing the purified air and avoiding accidental contact with the electric fan which, in turn, is protected inside by a further protective grill. These fins can only be removed in the event of extraordinary maintenance or repair operations. In all cases, before removing a safety device, it is necessary to cut off the electrical power.

NEVER INSTALL OR START THE MACHINE WITHOUT THE DIFFUSION FINS.

4.2 ELECTRICAL SAFETY DEVICES

The machine is provided with a door, through which access to the filters is permitted so as to carry out normal maintenance. This door is provided with a pin which actuates a safety switch, which cuts off the power supply if the door is opened without first cutting off the power by disconnecting the plug.

CUT OFF THE POWER SUPPLY BEFORE CARRYING OUT ANY OPERATION ON THE MACHINE.

The pin which actuates the microswitch must not be modified for any reason, and must not be blocked in the closed position in any way so as not to compromise safety. If the microswitch is broken the machine will stop. Contact the technical service for the replacement of this component.

4.2.1 Electronic circuit protection devices

The electronic circuit is provided with a series of protection devices which automatically cut off the high voltage whenever a machine malfunction occurs which could lead to its breakdown. There is a thermal fuse inside the machine (available only for the versions AFC System and NATURE System) which cuts off the power supply if a short circuit occurs in the electronic section down-line from the transformer.

There is a mains protection fuse in the power plug which cuts off the power to the machine in the event of short-circuiting of the transformer.

4.3 Fuse

Inside the machine is inserted a fuse, which you can find as follows:

- cut off the power supply of the machine
- open the door
- remove the cell and pre-filter
- open the fuse holder

Blown fuses must be replaced with others with the same characteristics and has to be done by the technical service.

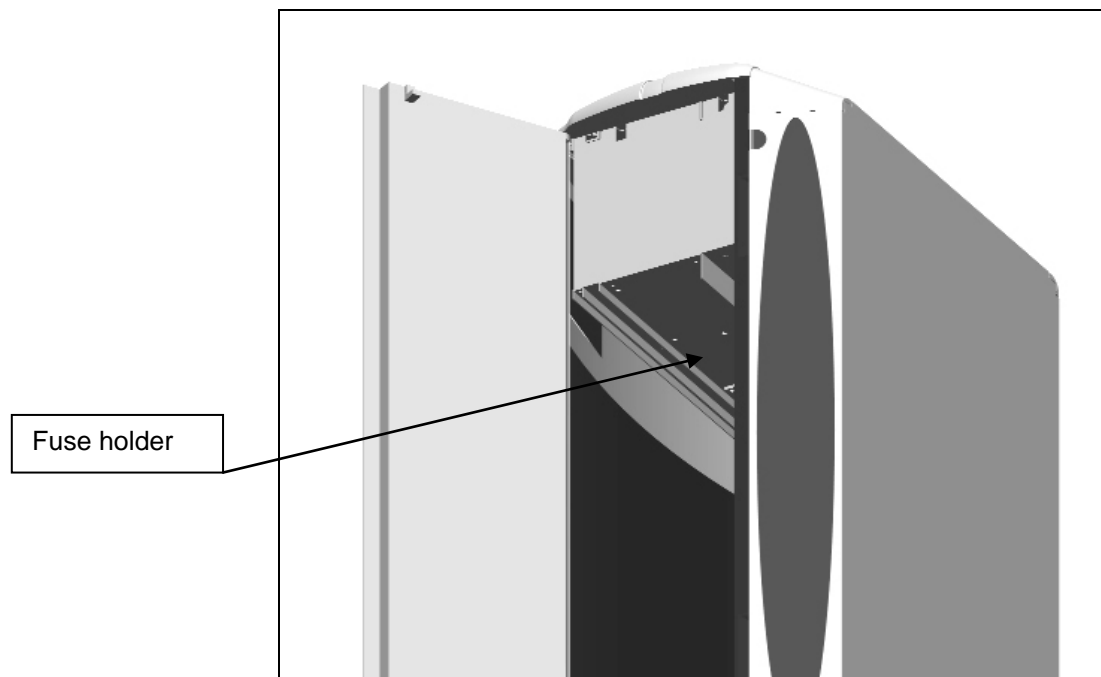

5

MAINTENANCE OF THE MACHINE

General maintenance of the machine by specialised technicians is recommended at least once a year (usually in summer). This allows the machine to be in a perfect state of efficiency.

5.1 REPLACEMENT OF THE ION-EMITTER NEEDLES



Support plate of the ion emitter

The emitter needles deteriorate as time goes by, consequently once a year it is necessary to replace them.

For this it is necessary to:

- disconnect the power supply
- open the door and take the internal filters out
- with a screwdriver take out the fixing screws of the support plates of the emitter needles (fig. A)
- pull out the needle fixed on the plate (fig. B)
- replace the needle
- fix the support plate on the same place from where it was taken out
- insert the filters

Fig. A

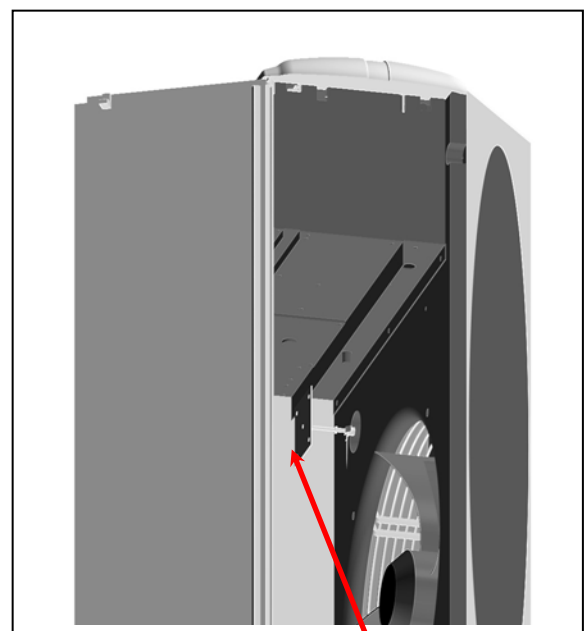

Fig. B

Plate with

needles

6

ORDINARY MAINTENANCE

Ordinary maintenance involves:

- maintenance of the filter unit
- general inspection of the machine

Extraordinary maintenance is carried out by specialised personnel.

6.1 FILTER MAINTENANCE

To carry out filter maintenance, it is necessary to gain access to them through the provided door and consists in washing the filter cell and the metal pre-filter

6.1.1 Access Door

For opening the machine, pull the door on the upper part.

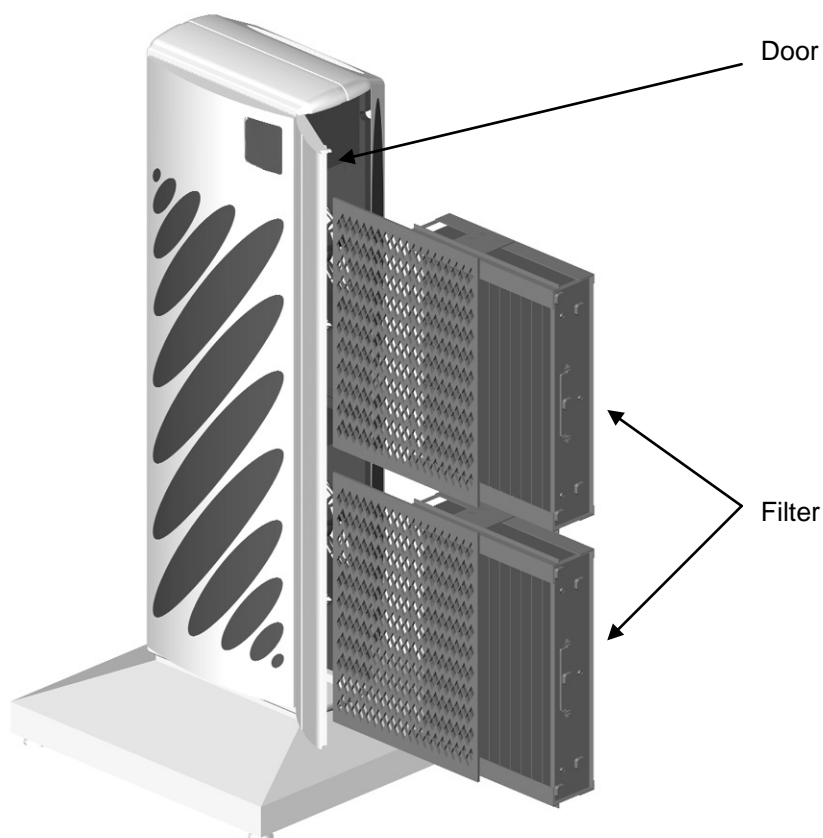

6.1.2 *Washing the filters*

Filter maintenance is important both for the correct operation of the machine and for constant performance with the passage of time. The following materials are required for maintenance:

- 1) Two plastic trays, one with the bottom raised 2-3 cm for decanting the dirt. As an alternative to the raised bottom, use a stainless steel frame.
- 2) Non-corrosive detergent for washing the electrostatic cells, supplied by an authorised dealer.
- 3) A rubber tube for rinsing the filters.
- 4) Vinegar.

Prepare the tray with the raised bottom with warm water (max 45°C). Dilute the detergent in the proportions indicated on the label of the detergent itself. Put the vinegar and water in the other (1 litre of vinegar for every 20 litres of water).

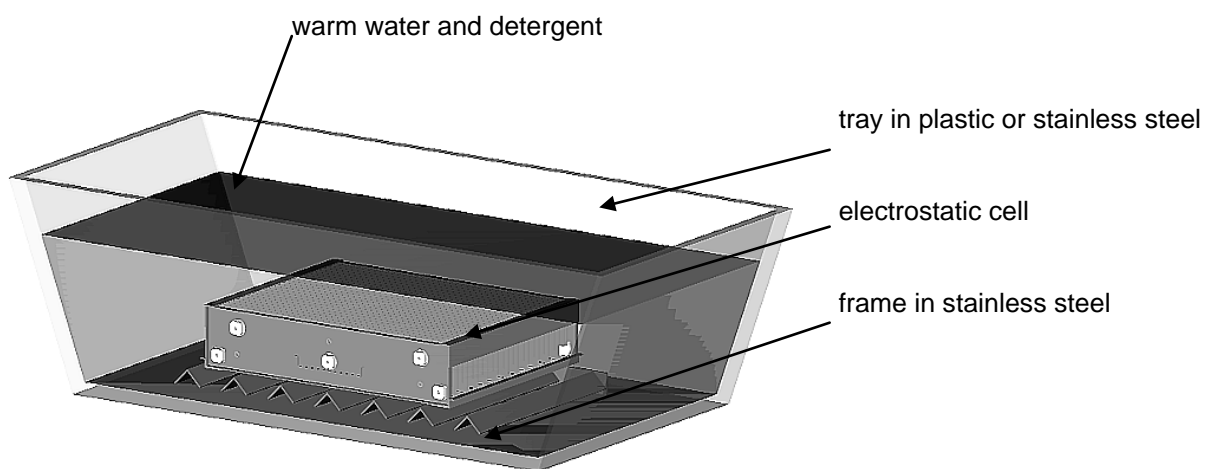

To wash, proceed as follows:

- a) immerse the electrostatic cell in the tray with the detergent and soak until the dirt is dissolved
- b) remove the electrostatic cell and rinse thoroughly with running water, taking care not to break the ionisation wires
- c) immerse the cell in the tray containing the water and vinegar and leave to soak for 5-10 minutes.

rinsing with current water

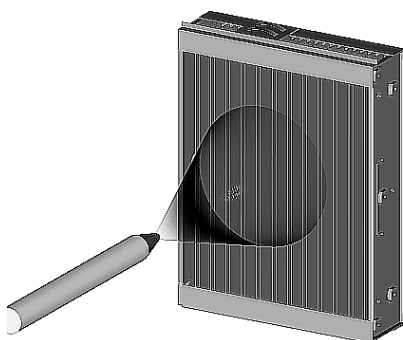

drying

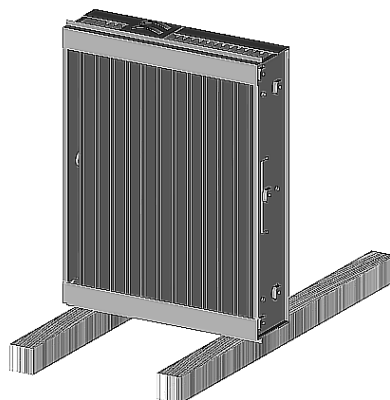

- d) remove the cell and leave it to dry in a warm place, keeping it raised from the ground by wooden strips (ovens with a maximum temperature of 60°C are tolerated).
- e) examine the state of the ionisation wires, stretching them slightly to check their mechanical strength. Use a cotton flock and methylated spirits to remove any residual traces of dirt.
- f) Ensure that the cell is thoroughly clean and dry before reinstalling it.

When maintaining the pre-filter, first remove the dust deposited in it using an ordinary vacuum cleaner. Then proceed with washing as follows:

- a) Immerse the pre-filter in the tray containing the detergent diluted in warm water and leave to soak for about half an hour
- b) Remove the pre-filter from the tray and rinse thoroughly with water
- c) Leave to dry in a warm ventilated environment

6.2 GENERAL INSPECTION OF THE FILTERS

The state of the filters must be inspected every time they are washed so as to prevent air cleaner malfunction and problems.

INSPECTION	FAULT	OPERATION
ionisation wires	breakage of a wire	change the ionisation wire
ionisation wires	rough surface with material deposits	clean the wire with a cloth soaked in alcohol or replace
ceramic insulators	dirty with material deposits	wash the cell again
ceramic insulators	breakage or presence of cracks	replace the insulators
high voltage terminal strip	burning caused by high voltage	replace the high voltage terminal strip

The following inspections must be made on the filters:

- check that the internal mesh of the pre-filter is compact and that no wires protrude from the containing meshes
- check that the frame is not deformed or damaged

If the pre-filter is badly damaged, replace it with a new one

6.3 CLEANING THE MACHINE

To clean the outside, use a cloth sprayed with methylated spirits. Use a brush with soft bristles to clean the air outlet fins. To clean the inlet grill, use a vacuum cleaner with a dusting attachment.

6.4 REPLACEMENT OF THE PRE-FILTER ON THE GRID

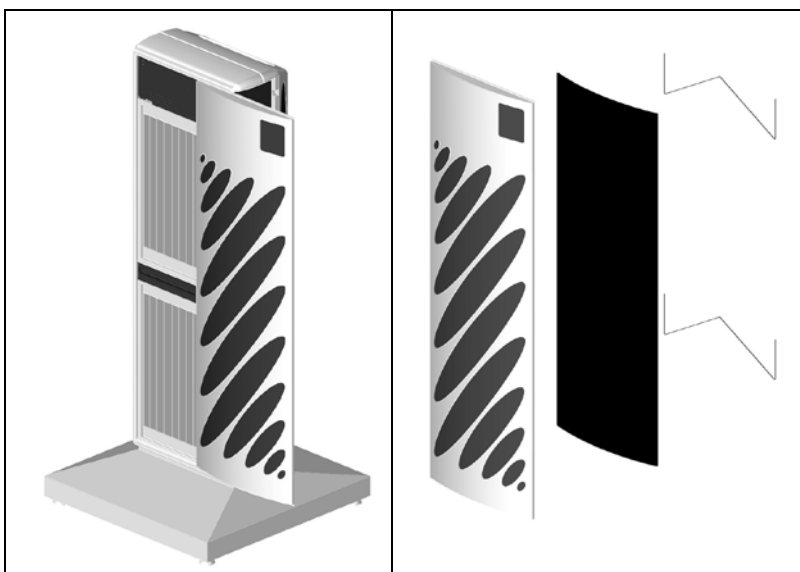

It is necessary to replace the pre-filter of man-made fibre fixed on the suction grid regularly.

Follow the instructions :

- disconnect the power supply
- open the door
- take the door out forcing on the hinges until they are released from the plastic supports
- take out the connecting jack between the synoptic on the grid and the box of the circuit
- pull the grid out completely
- take out the back locks which fix the fibre inside the grid
- pull the dirty fibre out and replace it with a new one
- close the machine

7

AVAILABLE VERSIONS

The machine is manufactured in two versions. For distinguishing which version you have, you should control the label placed outside on the machine or to check the control panel.



Nature System[®] is the Top version and identifies the Environmental Revitalizer. It is used a digital technology for the controlling of all functions. The operations carried out by this machine are reported in the following definitions.

NATURE SYSTEM[®]

Identifies the method used in confined environments to obtain an air quality as close as possible to a "natural" one.

ENVIRONMENTAL REVITALISATION (RIVITALIZZAZIONE AMBIENTALE)[®]

Identifies the operation carried out by the apparatus to create ionic equilibrium, inside a confined environment, as close as possible to the ideal one for **well-being**.

ENVIRONMENTAL REVITALIZER (RIVITALIZZATORE AMBIENTALE)[®]

Identifies the apparatus which, in an equilibrated manner, carries out various complex operations with the maximum security and reliability to render the environment comfortable, with characteristics similar to natural ones uncontaminated by the presence of man.

HIGH-EFFICIENCY FILTERING

Identifies the operation of purifying the confined environment. This operation is carried out with an efficiency which is constant with time and in a completely autonomous manner, thanks to the microprocessor which guarantees optimal performance whatever situations it is used in.

NIGHT-TIME DEODORIZATION

Identifies the work carried out by the Revitalizer during the night to eliminate the stagnant odour from the premises as well as typical residual odours in badly-aired environments.
The air is fresher and bracing the next day.

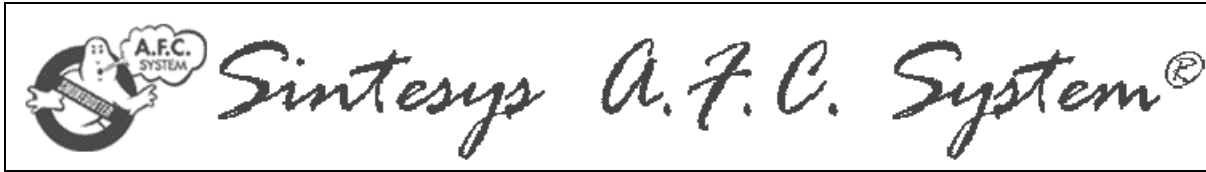

AFC SYSTEM® is the Top version of Environmental Air Purifiers and is using a digital technology for the controlling of its functions. The operations carried out by this machine are reported in the following definitions:

AFC SYSTEM®

Identifies the method used by the microprocessor of the machine to gesture in complete autonomously way the parameters of the filtration, depending from the chosen performance of function and the level of saturation of the electrostatic cell.

HIGH-EFFICIENCY FILTERING

Identifies the operation of purifying the confined environment. This operation is carried out with an efficiency which is constant with time and in a completely autonomous manner, thanks to the microprocessor which guarantees optimal performance whatever situations it is used in.

8

NATURE SYSTEM®

The NATURE SYSTEM® is composed of the following elements:

Electronic control of environmental revitalisation (rivitalizzazione ambientale®)

The System automatically carries out all the controls and gives the commands to the Environmental Revitalisation along with the information required on the operating status of the apparatus.

Infrared remote control unit

The remote control unit allows the user to control the operation of the Revitalizer from a distance of about 6÷7 metres; in particular, the air flow can be varied.

High-efficiency filtration unit

This element feeds the filtering System in a completely automatic manner, maintaining constant high efficiency in all situations.

Environmental Revitalisation Unit

This element feeds environmental revitalisation in an optimal manner to reach ionic equilibrium in completely different situations and environments.

8.1 CONTROL PANEL

All information regarding the operating status of the machine is displayed on the control panel.

The control panel allows the user to:

- select the air flow
- activate/deactivate environmental revitalisation
- turn off any alarms indicating apparatus malfunctions
- constantly control all the functions relating to operation (air flow, environmental revitalisation, filtration efficiency, alarm situation).

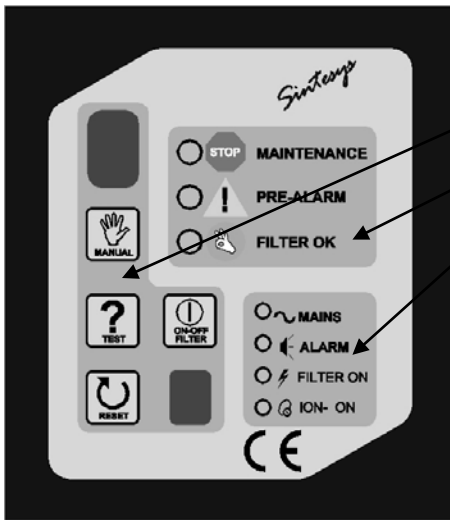

The control panel is divided in three zones:
 1 – COMMANDS AND VISUALISATION OF THE SPEED
 2 – FILTERING STATUS
 3 – OPERATION OF THE APPARATUS

The devices which permit manual operation and visual control of the operating conditions are given here below.

8.1.1 DISPLAY

When the machine works normally, the single-figure display shows the operating air flow (0-1-2-3). If, on the other hand, the letter F appears, this means that operation of the electrostatic cell is not correct. The reason may be a deposit of pollutant on the surface of the ionisation wires (see paragraph "ELECTRONIC CIRCUIT ALARM SIGNALS").

If the letter F appears together with the indication ALARM, the operation of the Revitaliser does not stop, however it is an indication of efficiency reduction.

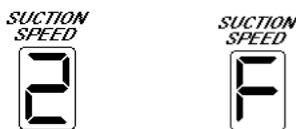

8.1.2 RECEIVER



The receiver permits the reception of the signal coming from the infrared remote control unit to obtain speed changes, activation of the night-time deodorization phase or switching off of the apparatus; if one of the four remote control buttons has been pressed, the Led flashes for about 1 second.

8.1.3 **MANUAL, TEST, ON-OFF FILTER AND RESET BUTTONS**

The MANUAL button allows the air flow to be modified manually (0-1-2-3); the setting is memorised and maintained even if there is a power failure. The machine can be turned off by turning to flow 0 (fan off).



Pressing the button indicated, a test on the operation of the electronic circuit signals is carried out. The air purifier is in perfect operating conditions only if all the Leds go on. Otherwise call our service network.



The ON/OFF button is for activating/deactivating the filtration or revitalisation function. It is used when you need to completely dry the filtering unit after washing, or to use the machine for the ventilation function only.



The RESET button is for turning off the ALARM signal if the circuit protection device has tripped as a result of a continuous discharge or short circuit in the electrostatic cells. If the alarm persists even after resetting, call the technical service.



8.1.4 **OPERATION OF THE MACHINE**

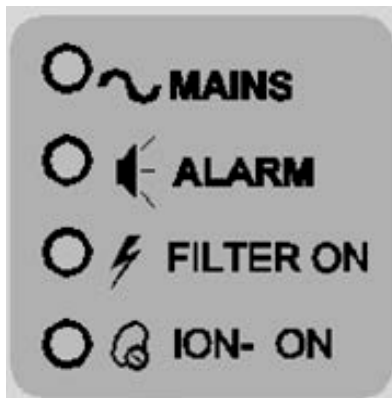

These four LEDs indicate the operating status of the environmental Revitalizer:

- MAINS (green Led): power on (constant)
- ALARM (red Led): when this is on, it means that there is a problem with the high-efficiency filtration unit. All the filtration and revitalisation functions are stopped (call the technical service).
- FILTER ON (yellow Led): when this is on, it means that filtering is on.
- ION- ON (yellow Led): when this is on, it means that revitalisation is on (ionic re-equilibrium).

8.1.5 FILTERING STATUS

The three Leds indicate the state of filtering efficiency and therefore only go on when filtration is activated; only one Led lights up at a time. The indications on filtering status are:

	<p>- MAINTENANCE (red Led):</p>	<p>saturated filter to be cleaned or replaced (maintenance); in this case all the filtering and revitalisation functions are stopped.</p>
	<p>- PRE-ALARM (yellow Led):</p>	<p>efficient filtering but not at the maximum levels (pre-alarm)</p>
	<p>- FILTER OK (green Led):</p>	<p>high filtering efficiency</p>

8.2 INFRARED REMOTE CONTROL UNIT

The remote control unit allows you to control the Revitalizer, modifying the air flow and activating night-time revitalisation from a distance of about 6-7 metres. The following functions are provided:

- 1st FAN SPEED key: sets the "maintenance" flow (room half empty)
- 2nd FAN SPEED key: sets the "normal use" flow (room half-full)
- 3rd FAN SPEED key: sets the "emergency" flow (room crowded)
- OFF key: turns off the air purifier

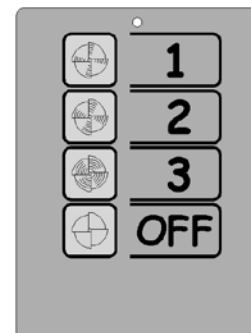

How to use: point the remote control towards the control panel, taking care that you are in line with it at a distance no greater than 6-7 metres.

When one of the four keys is pressed, the red LED at the top of the remote control unit goes on to indicate that transmission is in progress. Almost at the same time, the red LED located in the receiver of the control panel flashes, indicating that the signal has been received.

The infrared transmitter is powered by a 9-volt battery, type PP3 (transistor).

8.3 POWER SUPPLY AND ANTI BLACK-OUT SYSTEM

The machine is powered by a mains voltage of 210 to 240V AC at 50 Hz.

A momentary (or prolonged) power failure does not cause the resetting of the machine functions and when power is restored the machine goes back into operation on its own.

ATTENTION: always connect the apparatus to the earth to protect persons, things and animals and respect CEI 11-29, CEI 64-8, and EN 60335 standards.

8.4 ENVIRONMENTAL REVITALISATION (RIVITALIZZAZIONE AMBIENTALE®)

The Revitalizer revitalises the air in a confined environment in a completely automatic manner and until the pollutant has been completely cleaned from the environment.

This phase is automatically activated after the complete purification of the air so that the phenomenon of electrostatic charging of the pollutants cannot occur as they would be deposited on the walls, on the furnishings and in the respiratory tract. The revitalisation of the air is for re-establishing the ionic equilibrium in the environment after all the pollutants have been cleansed from it.

During the normal operation of this phase, the yellow led ION-ON lights up with fixed light.

Table A Advantages of negative ionisation

ASPECTS INVOLVED	EFFECTS PRODUCED
Air quality	Improvement
Odours	Reduction
Arterial pressure	Reduction
Cardiovascular system	Improvement
Metabolism	Increase
Allergies	Reduction
Respiratory capacity	Improvement
Insomnia	Reduction
Mental concentration	Increase

The Revitalizer only goes off when the user turns the operating capacity to 0 by means of the control panel or the remote control unit, or if an alarm trips due to malfunction arising from problems in the electrostatic cells or in the electronic parts (ALARM, MAINTENANCE). In this case only the fan works.

8.5 PURIFICATION

The Revitalizer purifies the air by means of a high-efficiency electrostatic filter whose operation is governed by an electronic circuit which guarantees optimal and constant performance with time in any situation.

8.6 NORMAL CONDITIONS OF OPERATION

In normal conditions of operation the Revitalizer alternates the purification phase with the revitalisation phase, so that the environmental conditions described above can be created.

The purification phase is indicated by the yellow FILTER-ON and the green FILTER-OK Leds lighting up, while the revitalisation phase is shown by the yellow Led ION-ON lighting up (without flashing).

8.7 NIGHT-TIME REVITALISATION WITH ENVIRONMENTAL DEODORIZATION

If the Revitalizer is off or in flow position 2 or 3, this phase is activated by pressing button 1 of the infrared remote control unit three times consecutively, while if the flow is 1, the button should be pressed twice. During this phase, night revitalisation is signalled by the flashing of the yellow ION-ON and FILTER ON leds, and must only be used during the period when the premises are not occupied by people.

After this activation it is possible to change the fan speed.

The benefits which can be found with night-time revitalisation are especially evident the following morning when an air quality at a level never found before will be noted.

Night-time revitalisation must be turned off in the morning by pressing the OFF button on the remote control unit or turning the display to 0 (zero) by means of the MANUAL button; then activate the daytime operating phase by turning the Revitalizer to one of the 3 speeds available, by means of the remote control unit or the MANUAL button.

8.8 SIGNALS

The electronic control of this apparatus provides the user visually with all the information on operation required for correct use, and makes available the means for fast checking to seek any small anomalies, by means of the RESET-TEST-ON/OFF FILTER buttons.

8.9 STATE OF FILTRATION EFFICIENCY

As described in paragraph CONTROL PANEL, the three Leds of FILTRATION STATUS provide indications on the state of filtration efficiency.

The environmental revitalisation cycle remains active until optimal air filtration is obtained, indicated by the FILTER OK or PRE-ALARM Leds. If optimal filtration is not guaranteed, the red Led MAINTENANCE, will go on and the automatic revitalisation cycle will be deactivated (FILTER ON and/or ION-ON Leds off). In this case only the electric fan will run.

To turn off the alarm, simply turn off the Revitalizer, turning it to 0 (zero), and then start it again at any one of the three speeds; if the operating condition with the red MAINTENANCE Led persists, carry out a general check of the filtering system, see ORDINARY MAINTENANCE.

8.10 OPTIMAL APPLICATION OF THE REVITALIZER

NATURE SYSTEM® guarantees restoration of the conditions of purity and ionic re-equilibrium in all contaminated environments. You get the maximum results with NATURE SYSTEM® if you first identify the particular type of problem the Revitalizer must solve. For this reason, eight types of Revitalizer suitable for specific applications have been defined.

- TYPE **A**: suitable for premises such as bars, casinos, discos, pubs, amusement arcades, etc.
- TYPE **B**: suitable for premises such as restaurants, pizzeria, cafes, ice-cream parlours, butcher shops, etc.
- TYPE **C**: suitable for premises such as shops and stores for food, clothing, electrical appliances, etc.
- TYPE **D**: suitable for premises such as offices, computer rooms, professional offices, waiting rooms, laboratories, etc.
- TYPE **E**: suitable for premises such as hospital wards, and for treating illnesses of the respiratory tract, allergies, etc.
- TYPE **F**: suitable for environments in built-up areas and with high environmental pollution
- TYPE **G**: suitable for environments with high radon concentrations
- TYPE **H**: suitable for garden nurseries, flower shops and flower-growing in general

8.11 ELECTRONIC CIRCUIT ALARM SIGNALS

The electronic circuit detects every cause of imperfect air filtration. If there is a slight drop in the efficiency of the machine, the yellow PRE-ALARM Led will light up. If, however, the drop in efficiency is greater, filtering will be blocked completely and the red MAINTENANCE Led will go on. These signals can also come on because of faults in the physical state of the electrostatic cells.

TYPE OF ALARM	CAUSE	OPERATION
yellow LED on PRE-ALARM or letter F on the display	electrostatic cell dirty	carry out normal maintenance
yellow LED on PRE-ALARM	electrostatic cell not properly clean	if small dirty areas have remained, washing must be carried out again
yellow LED on PRE-ALARM	electrostatic cell damp	dry the cell thoroughly and particularly in the zone of the insulators
yellow LED on PRE-ALARM	electrostatic cell not properly rinsed	there may be detergent on the insulators; the cell must be thoroughly rinsed again
yellow LED on PRE-ALARM	small bodies trapped between the collection blades	the foreign bodies deposited on the blades must be removed
red LED on MAINTENANCE	electrostatic cell very dirty	carry out normal maintenance as soon as possible
red LED on MAINTENANCE and ALARM	electrostatic cell very dirty because of breakage of an ionisation wire	the wire must be removed and replaced immediately
red LED on MAINTENANCE and ALARM	electrostatic cell short circuited due to collection blade being bent	the blade must be straightened (call a specialised technician)
red LED on MAINTENANCE and ALARM	electrostatic cell short circuited by body trapped between the blades	the body must be removed taking care not to break the ionisation wires
letter F on the display	ionisation wires dirty or oxidised	clean the wires with a rag soaked in alcohol; if the problem persists, the wires must be replaced

It is possible that the operating status of the Revitalizer can be modified with some infrared remote control units for television sets or banknote readers for videogames by modifying the speed fan and the status of the machine. Check that this does not happen by pointing the TV remote control at the Revitalizer and press the ON/OFF button.

8.12 ELECTRONIC CIRCUIT ANOMALOUS SIGNALS

In some cases signals such as the following may occur:

- the display goes off momentarily,
- the letter 'P' on the display goes on,
- the letter 'N' on the display goes on.

The first case is the automatic circuit protection tripping when ionisation voltage has been discharged to the earth. In this case, it is necessary to check that the pre-filter is properly fitted in its seat and that it does not oscillate when the Revitalizer is working.

The other two cases are due to activation of particular test programs due to the simultaneous pressure of two buttons on the control panel of the circuit. To eliminate this activation, first disconnect the power plug and wait 5-10 seconds before putting it back in.

If the electronic circuit is damaged, fault signals of the following kind may occur:

- more than one of the filter efficiency Leds go on at the same time
- fan runs without any speed indication on the display
- no fan speed variation or fan fails to run
- the ALARM and MAINTENANCE Leds go on with indication of the operating speed without the filter cell being inserted.

In these cases you must call the nearest service centre.

9

A F C S Y S T E M[®]

AFC SYSTEM[®]

The system automatically carries out all the controls and gives the commands to the high-efficiency filtration along with the information required on the operating status of the apparatus.

Infrared remote control unit

The remote control unit allows the user to control the operation of the machine from a distance of about 6÷7 metres; in particular, the air flow can be varied.

High-efficiency filtration unit

This element feeds the filtering System in a completely automatic manner, maintaining constant high efficiency in all situations.

9.1 CONTROL PANEL

All information regarding the operating status of the machine is displayed on the control panel.

The control panel allows the user to:

- select the air flow
- turn off any alarms indicating apparatus malfunctions
- constantly control all the functions relating to operation (air flow, filtration efficiency, alarm situation).

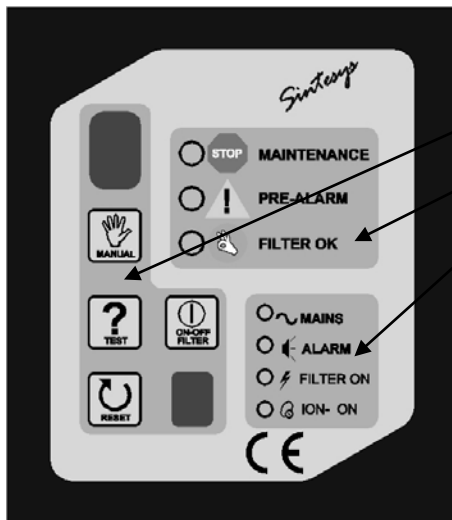

The control panel is divided in three zones:
1 – COMMANDS AND VISUALISATION OF THE SPEED
2 – FILTERING STATUS
3 – OPERATION OF THE APPARATUS

The devices which permit manual operation and visual control of the operating conditions are given here below.

9.1.1 DISPLAY

When the machine works normally, the single-figure display shows the operating air flow (0-1-2-3). If, on the other hand, the letter F appears, this means that operation of the electrostatic cell is not correct. The reason may be a deposit of pollutant on the surface of the ionisation wires (see paragraph "ELECTRONIC CIRCUIT ALARM SIGNALS").

If the letter F appears together with the indication ALARM, the operation of the machine does not stop, however it is an indication of efficiency reduction.



9.1.2 (RECEIVER)



The receiver permits the reception of the signal coming from the infrared remote control unit to obtain speed changes or switching off of the apparatus; if one of the four remote control buttons has been pressed, the Led flashes for about 1 second.

9.1.3 MANUAL, TEST, ON-OFF FILTER AND RESET BUTTONS

The MANUAL button allows the air flow to be modified manually (0-1-2-3); the setting is memorised and maintained even if there is a power failure. The machine can be turned off by turning to flow 0 (fan off).



Pressing the button indicated, a test on the operation of the electronic circuit signals is carried out. The air purifier is in perfect operating conditions only if all the Leds go on. Otherwise call our service network.



The ON/OFF button is for activating/deactivating the filtration function. It is used when you need to completely dry the filtering unit after washing, or to use the machine for the ventilation function only.



The RESET button is for turning off the ALARM signal if the circuit protection device has tripped as a result of a continuous discharge or short circuit in the electrostatic cells. If the alarm persists even after resetting, call the technical service.



9.2 OPERATION OF THE MACHINE

These four Leds indicate the operating status of the Air Purifier:



- MAINS (green Led): power on (constant))
- ALARM (red Led): When this is on, it means that there is a problem with the high-efficiency filtration unit. All the filtration functions are stopped (call the technical service).
- FILTER ON (yellow Led): When this is on, it means that filtering is on.
- ION- ON (yellow Led): **This function is not available in AFC System version.**

9.3 FILTERING STATUS

The three Leds indicate the state of filtering efficiency and therefore only go on when filtration is activated; only one Led lights up at a time. The indications on filtering status are:



- MAINTENANCE (red Led): saturated filter to be cleaned or replaced (maintenance); in this case all the filtering functions are stopped.
- PRE-ALARM (yellow Led): efficient filtering but not at the maximum levels (pre-alarm)
- FILTER OK (green Led): high filtering efficiency

9.4 INFRARED REMOTE CONTROL UNIT

The remote control unit allows you to control the machine, modifying the air flow from a distance of about 6-7 metres. The following functions are provided:

- 1st FAN SPEED key: sets the "maintenance" flow (room half empty)
- 2nd FAN SPEED key: sets the "normal use" flow (room half-full)
- 3rd FAN SPEED key: sets the "emergency" flow (room crowded)
- OFF key: turns off the air purifier

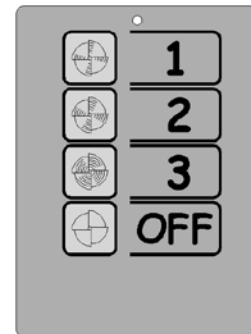

How to use: point the remote control towards the control panel, taking care that you are in line with it at a distance no greater than 6-7 metres.

When one of the four keys is pressed, the red LED at the top of the remote control unit goes on to indicate that transmission is in progress. Almost at the same time, the red LED located in the receiver of the control panel flashes, indicating that the signal has been received.

The infrared transmitter is powered by a 9-volt battery, type PP3 (transistor).

9.5 POWER SUPPLY AND ANTI BLACK-OUT SYSTEM

The machine is powered by a mains voltage of 210 to 240V AC at 50 Hz.

A momentary (or prolonged) power failure does not cause the resetting of the machine functions and when power is restored the machine goes back into operation on its own.

ATTENTION: always connect the apparatus to the earth to protect persons, things and animals and respect CEI 11-29, CEI 64-8, and EN 60335 standards.

9.6 PURIFICATION

The Air Purifier purifies the air by means of a high-efficiency electrostatic filter whose operation is governed by an electronic circuit which guarantees optimal and constant performance with time in any situation.

9.7 SIGNALS

The electronic control of this apparatus provides the user visually with all the information on operation required for correct use, and makes available the means for fast checking to seek any small anomalies, by means of the RESET - TEST - ON/OFF FILTER buttons.

9.8 STATE OF FILTRATION EFFICIENCY

As described in paragraph CONTROL PANEL, the three Leds of FILTRATION STATUS provide indications on the state of filtration efficiency.

The purifying cycle remains active until optimal air filtration is obtained, indicated by the FILTER OK or PRE-ALARM Leds. If optimal filtration is not guaranteed the red Led MAINTENANCE will go on (Led FILTER ON off). In this case only the electric fan will run.

To turn off the alarm, simply turn off the machine, turning it to 0 (zero), and then start it again at any one of the three speeds; if the operating condition with the red MAINTENANCE Led persists, carry out a general check of the filtering system, see ORDINARY MAINTENANCE.

9.9 ELECTRONIC CIRCUIT ALARM SIGNALS

The electronic circuit detects every cause of imperfect air filtration. If there is a slight drop in the efficiency of the machine, the yellow PRE-ALARM Led will light up. If, however, the drop in efficiency is greater, filtering will be blocked completely and the red MAINTENANCE Led will go on. These signals can also come on because of faults in the physical state of the electrostatic cells.

TYPE OF ALARM	CAUSE	OPERATION
yellow LED on PRE-ALARM or letter F on the display	electrostatic cell dirty	carry out normal maintenance
yellow LED on PRE-ALARM	electrostatic cell not properly clean	if small dirty areas have remained, washing must be carried out again
yellow LED on PRE-ALARM	electrostatic cell damp	dry the cell thoroughly and particularly in the zone of the insulators
yellow LED on PRE-ALARM	electrostatic cell not properly rinsed	there may be detergent on the insulators; the cell must be thoroughly rinsed again
yellow LED on PRE-ALARM	small bodies trapped between the collection blades	the foreign bodies deposited on the blades must be removed
red LED on MAINTENANCE	electrostatic cell very dirty	carry out normal maintenance as soon as possible
red LED on MAINTENANCE and ALARM	electrostatic cell very dirty because of breakage of an ionisation wire	the wire must be removed and replaced immediately
red LED on MAINTENANCE and ALARM	electrostatic cell short circuited due to collection blade being bent	the blade must be straightened (call a specialised technician)
red LED on MAINTENANCE and ALARM	electrostatic cell short circuited by body trapped between the blades	the body must be removed taking care not to break the ionisation wires
letter F on the display	ionisation wires dirty or oxidised	clean the wires with a rag soaked in alcohol; if the problem persists, the wires must be replaced

It is possible that the operating status of the machine can be modified with some infrared remote control units for television sets or banknote readers for videogames by modifying the speed fan and the status of the machine. Check that this does not happen by pointing the TV remote control at the Air Purifier and press the ON/OFF button.

9.10 ELECTRONIC CIRCUIT ANOMALOUS SIGNALS

In some cases signals such as the following may occur:

- the display goes off momentarily,
- the letter 'P' on the display goes on,
- the letter 'N' on the display goes on.

The first case is the automatic circuit protection tripping when ionisation voltage has been discharged to the earth. In this case, it is necessary to check that the pre-filter is properly fitted in its seat and that it does not oscillate when the machine is working.

The other two cases are due to activation of particular test programs due to the simultaneous pressure of two buttons on the control panel of the circuit. To eliminate this activation, first disconnect the power plug and wait 5-10 seconds before putting it back in.

If the electronic circuit is damaged, fault signals of the following kind may occur:

- more than one of the filter efficiency Leds go on at the same time
- fan runs without any speed indication on the display
- no fan speed variation or fan fails to run
- the ALARM and MAINTENANCE Leds go on with indication of the operating speed without the filter cell being inserted.

In these cases you must call the nearest service centre.

10 TECHNICAL DATA

model	capacity m ³ /h	dB	Watt	aliment. V - Hz	dimensions mm	weight kg	n° of cells	kind of installation	remote control
330r	speed 1 speed 2 speed 3			230 – 50		60	1	ceiling	YES
510r	speed 1 speed 2 speed 3			230 – 50		82	2	ceiling	YES

11 CERTIFICATIONS

All machines are in possession of certification which attests to the high quality of the air treated and the high quality of the materials used to build them.

11.1 CERTIFICATION C.N.R.

The machines are in possession of C.N.R. certification, which attests to the efficiency of filtration declared for each model and certifies that ozone production is much lower than the limits laid down in law. For further clarification or to receive this certification, contact the manufacturer.

11.2 CERTIFICATION OF COMPONENTS

The electrical components used for the construction are being certified or are in possession of ISO29000 and quality certification meeting the requisites of current standards for electrical and mechanical safety, in accordance with EEC Machine Directive 89/392.