

Gas Leak Unit, VOC



User Manual

March 2013



Table of contents

- 1. Intended Use 4**
 - 1.1 Normal Mode 4
 - 1.2 Alarm Mode 4
 - 1.3 Fault Mode. 4
- 2 Operating Instruction 5**
 - 2.1 Description Keypad User Interface. 5
 - 2.2 Setting / Changing Parameters or Set points 6
 - 2.3 Code Levels 6
- 3 Menu Overview 7**
 - 3.1 Fault Management 8
 - 3.1.1 Acknowledge a Fault 8
 - 3.1.2 Error Memory 8
 - 3.1.3 System Errors 9
 - 3.2 Status Alarm 9
 - 3.3 Status Relay 10
 - 3.3.1 Manual Operation of the Relays 10
 - 3.4 Menu Measuring Values 11
 - 3.5 Menu Relay Parameters 12
 - 3.5.1 Relay Mode. 13
 - 3.5.2 Relay Function Static / Flash 13
 - 3.5.3 Latching Mode 13
 - 3.5.4 Horn Function 14
 - 3.5.5 External Relay Operation 15
 - 3.6.1 Activate - Deactivate MP 17
 - 3.6.2 Selection Gas Type. 18
 - 3.6.3 Measuring Range 19
 - 3.6.4 MP Signal. 19
 - 3.6.5 Threshold / Hysteresis. 19
 - 3.6.6 Delay of Alarm ON or OFF. 20
 - 3.6.7 Control Mode 20
 - 3.6.8 MP Fault Assigned to Alarm 20
 - 3.6.9 Alarm Assigned to Alarm Relay. 20
 - 3.6.10 MP Signal Assigned to Analog Output 21
 - 3.7 Menu System Parameters 22
 - 3.7.1 Service Mode 23
 - 3.7.2 Software version 23
 - 3.7.3 Maintenance Concept. 23
 - 3.7.4 Average Function 23
 - 3.7.5 Customer Password (Code 4) 24
 - 3.7.6 Analog Output 24
 - 3.7.7 Define the Failure Relay 24
 - 3.7.8 Power On Time. 24
- 4 Mounting / Electrical Connection 25**
 - 4.1 Electrical Connection 25



4.2 Connection Diagram26
4.3 Connector Block / Overview VOC Module27
5 Commissioning	28
5.1 Commissioning28
5.2 Checklist Commissioning29
6 Configuration and Parameter	30
6.1 Configuration Card of System Parameters.30
6.2 Configuration Card of Alarm Relays30
6.3 Configuration Card of Measuring Parameters31
7 Specifications	32
8 Gas Sensor	34
8.1 Description.34
8.2 VOC Measurements.34
9 Commissioning	35
10 Inspection and Service.	36
10.1 Inspection36
10.2 Exchange of Sensor Element36
11 Specification Gas Sensor	36
12. Levels to set in the ventilation system	37
13 Part Disposal	38
14 Notes and General Information.	38
14.1 Intended Product Application.38
14.2 Installers' Responsibilities.38
14.3 Maintenance38
14.4 Limited Warranty38



Gas Leak Unit

1. Intended Use

The Gas Leak Unit is used for measuring and controlling indoor air quality. The Gas Leak Unit is equipped with an internal gas sensor (MP01). One external gas transmitter (MP02) for toxic, combustible or refrigerant gases can be controlled additionally. Four alarm thresholds are freely adjustable for each Measuring Point (MP). Every alarm threshold can be assigned to one of the maximum 4 alarm outputs (RX). The Gas Controller can interface via the (0)4 to 20 mA or (0)2 to 10 V output signal with any compatible electronic analog control, DDC/PLC control or automation system.

The freely adjustable parameters and alarm threshold make a very flexible use within the gas measuring possible. Simple and comfortable commissioning is possible due to factory adjusted parameters.

The configuration parameter settings and operation can easily be performed without programming knowledge.

The intended sites within the ambient conditions as specified in the Technical Data are all areas being directly connected to the public low voltage supply, e.g. residential, commercial and industrial ranges as well as small enterprises (according to EN50 082).

The Gas Leak Unit must not be used in potentially explosive atmospheres.

1.1 Normal Mode

In normal mode, the gas concentrations of the active transmitters are continuously polled and displayed at the LCD display in a scrolling way. The controller also monitors the communication to all active transmitters.

1.2 Alarm Mode

If the gas concentration reaches the programmed alarm threshold, the alarm is started, the assigned alarm relay is activated and the red alarm LED is flashing. The set alarm can be read from the menu Alarm Status. When the gas concentration falls below the alarm threshold, the alarm is automatically reset. In latching mode, the alarm has to be reset manually in the menu Relay Status.

1.3 Fault Mode



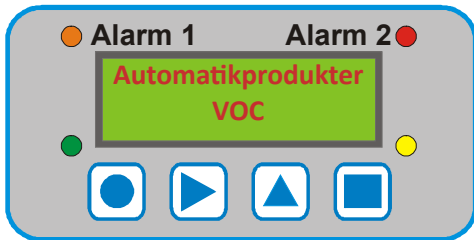

If the controller detects an analog signal outside the admissible range (< 3 mA - > 22 mA) from an active transmitter, the assigned fault relay is set and the error LED is blinking. The error is displayed in the menu Error Status in clear text. After removal of the cause, the error message is acknowledged in the menu Error Status.

2 Operating Instruction

The complete configuration, parameterization and service are made via keypad user interface in combination with the display screen. Security is provided via two password levels.



2.1 Description Keypad User Interface

-  Exits programming, returns to the previous menu level.
-  Enters submenus, save settings.
-  Scrolls up in main menu and submenus, increases or decreases a value.
-  Moves the cursor.

LED orange: Flashes when alarm one or more alarms are active.
Permanently on, when at least one of the relays is manually operated.

LED red: Flashes when alarm two or more alarms are active.
Permanently on, when at least one of the relays is manually operated.

LED yellow: Flashes at system or sensor failure or when maintenance needed.

LED green: Power LED

2.2 Setting / Changing Parameters or Set points

Open desired menu window.



Code window opens, if no code level approved.

After inputting the valid code the cursor jumps on the first position segment to be changed.



Push the cursor onto the position segment, which is to be changed.



Change the parameter / set point.



Save the changed value.

Finished

2.3 Code Levels

All inputs and changes are protected by a four-digit numeric code (= password) against unauthorised intervention. All menu windows are visible without entering a code.

Level 1: (1234)

Code level 1 allows the operator to acknowledge alarms and to manually activate the alarm relays.

Level 2:

Code level 2 is intended for the service technician to change parameters and set-points.

Level 3:

With code level 3 it is possible to register and deregister transmitters in addition to code level 1. This code is released by Automatikprodukter only in emergency situations.

Level 4:

Code level 4 is intended for updating the maintenance date. Normally the code is only known by the service technician and can be changed individually via code level 2.

The release of a code level is cancelled if no button is pushed within 15 minutes.

3 Menu Overview

The operation of the Gas Leak Unit, VOC, is effected by a simple and logical menu structure which is easy to learn.

The operating menu contains the following levels:

- Starting menu. Scrolling of the measuring points of all registered transmitters in 10-second intervals
- Main menu
- Submenu 1 and 2

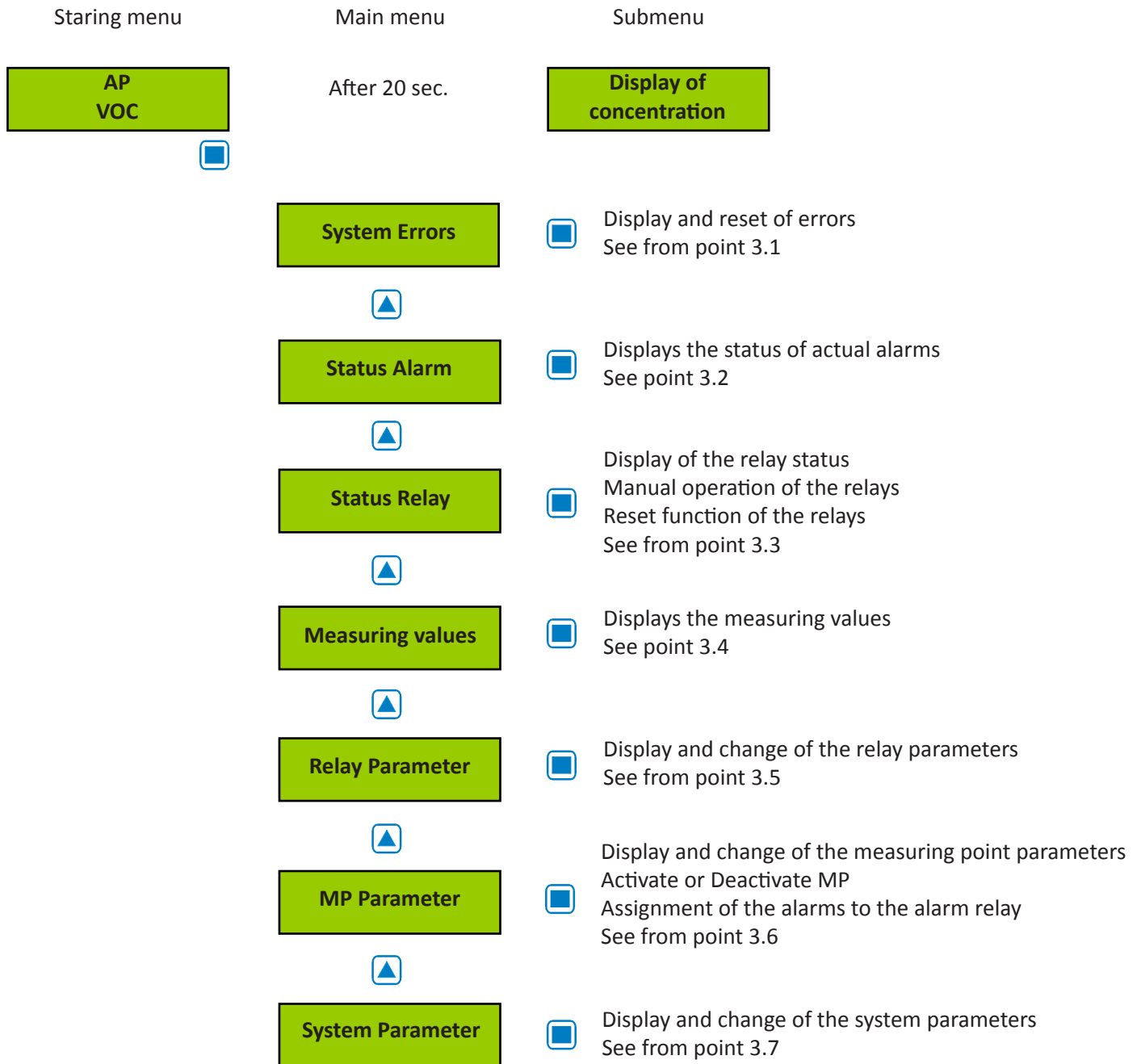

3.1 Fault Management

The integrated fault management records the last 15 faults in the menu “System Errors” with a stamp indicating how many days the error has already existed. The day counter subtracts “active ones” from 365. Additionally a record of the faults occurs in the “Error Memory”, which can be selected and reset only by the service technician.

An actual fault is displayed in plain text in the starting menu. The failure relay which is defined in the system parameter “Failure relay” is activated. The yellow LED in the front of the gas controller flashes.

In case of fault of a measuring point (MP) the alarms defined in the menu “MP Parameter” are activated additionally.

3.1.1 Acknowledge a Fault

Attention:

Acknowledging a fault is only possible after having removed the cause.

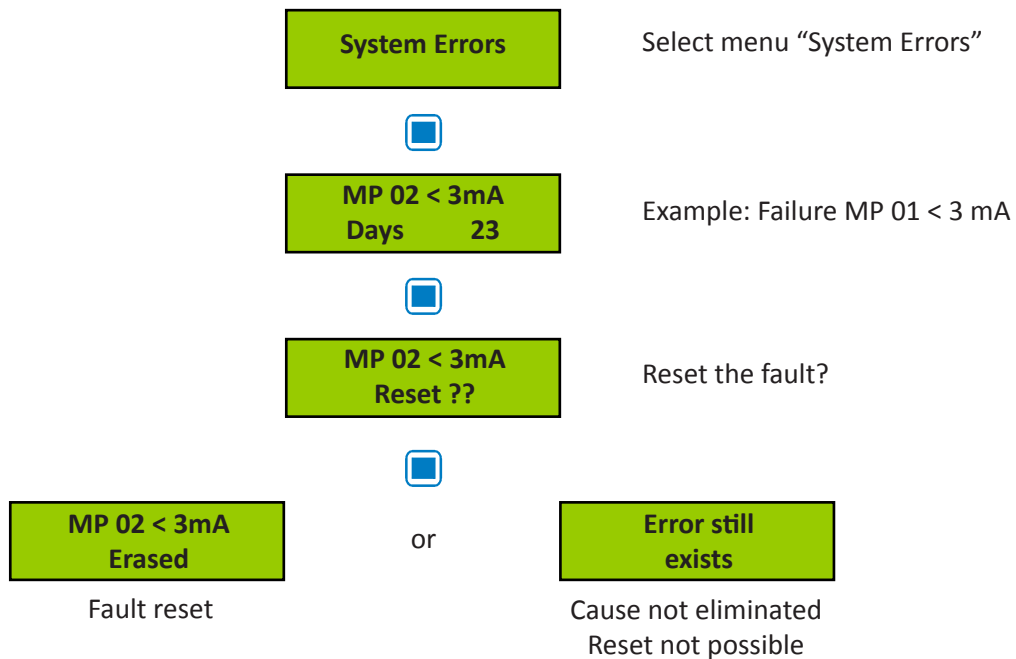

3.1.2 Error Memory

The menu “Error Memory” in the main menu “System Error” can only be opened via code level 2. In the error memory the last 15 faults are listed for the service technician even if they were already acknowledged in the menu “System Error”. The deletion of each individual message is effected in the same way as the reset of a fault.



3.1.3 System Errors

The following system error messages are recorded:

- MP 02 > 22 mA** Current signal at analog input > 22 mA / 11 VDC. (External Transmitter)
Cause: Short-circuit at analog input or transmitter not calibrated, transmitter defective.
Solution: Check cable to transmitter, make calibration, replace the transmitter.

- MP 02 < 3 mA** Current signal to analog input < 3 mA / 1,3 VDC. (External Transmitter)
Cause: Wire breaking at analog input or transmitter not calibrated, transmitter defective.
Solution: Check cable to transmitter, make calibration, replace the transmitter.

- GC Error:** Internal communication error I/O Board to LCD Board.
Cause: Internal error.
Solution: Change the Gas Controller module.

- Maintenance:** System maintenance is necessary.
Cause: Maintenance date exceeded.
Solution: Make the maintenance.

3.2 Status Alarm

Display of the actual alarms in plain text in the order of their arrival. Only those measuring points are displayed, where at least one alarm is active. Changes are not possible in this menu.

MP 01
A1 A2

Symbol	Description	Function
MP 01	Measuring (MP) Point No.	
AX	Status alarm	A1 = Alarm 1 ON A2 = Alarm 2 ON A3 = Alarm 3 ON A4 = Alarm 4 ON

3.3 Status Relay

The VOC has two alarm relays (R01 / R02) and two open collector outputs (R03 / R04). In the following description they are referred to as alarm relays.

Display of the actual status of alarm relays. Manual operation of the alarm relays.

R 01
OFF

Symbol	Description	Setting Status	Function
R 01	Relay No. 01		Select Relay No.
OFF	Status relay	OFF	OFF = Relay OFF (No gas alarm) ON = Relay ON (Gas alarm) Manual OFF = Relay manual OFF Manual ON = Relay manual ON

3.3.1 Manual Operation of the Relays

The manual operation of the alarm relays is managed in the menu "Status Relay". If a relay is in the manual ON or OFF status, the orange/ red alarm LED at the Gas Controller is lit continuously.

The external operation of the alarm relay via an assigned digital input has priority to the manual operation in the menu "Status Relay" and to gas alarm.

Relays manually operated in the menu "Status Relay" are deleted again by selecting the function "Automatic".

Acknowledging the relays in latching mode is also effected in this menu.

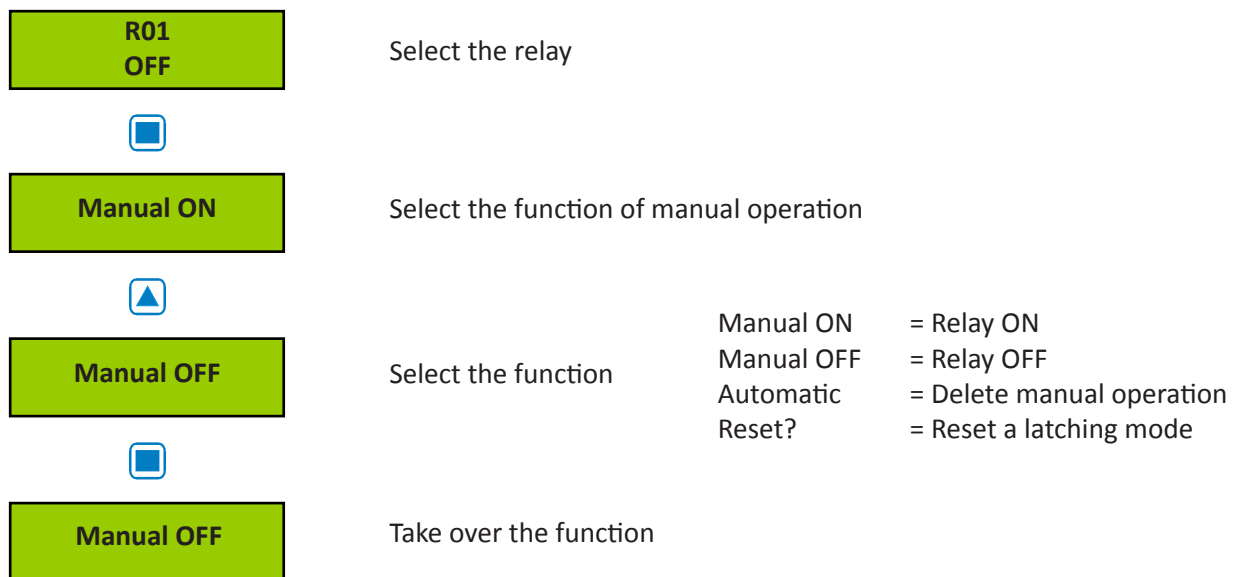

3.4 Menu Measuring Values

This menu is for displaying the current value (CV) or the average value (AV) with gas unit and gas type for each active measuring point according to the defined mode of control (CV or AV mode). For gas type CO both values are displayed together.

**MP 01 VOC ppm
33 CV**

Symbol	Description	Setting Status	Function
MP 01	Measuring P. No.		Selection of MP No
VOC	Gas type	VOC	See 3.6.2
ppm	Gas unit		See 3.6.2
CV	Current value	CV	Current value of gas concentration
AV	Average value		Average value (10 measured values within the time unit)
*	Control mode		Display of selected control mode (CV or AV)
Not active	Status MP	Not active	MP not active
Error	Fault MP		Current signal < 3 mA or > 22 mA

3.5 Menu Relay Parameters

Display and change of the parameters for each alarm relay

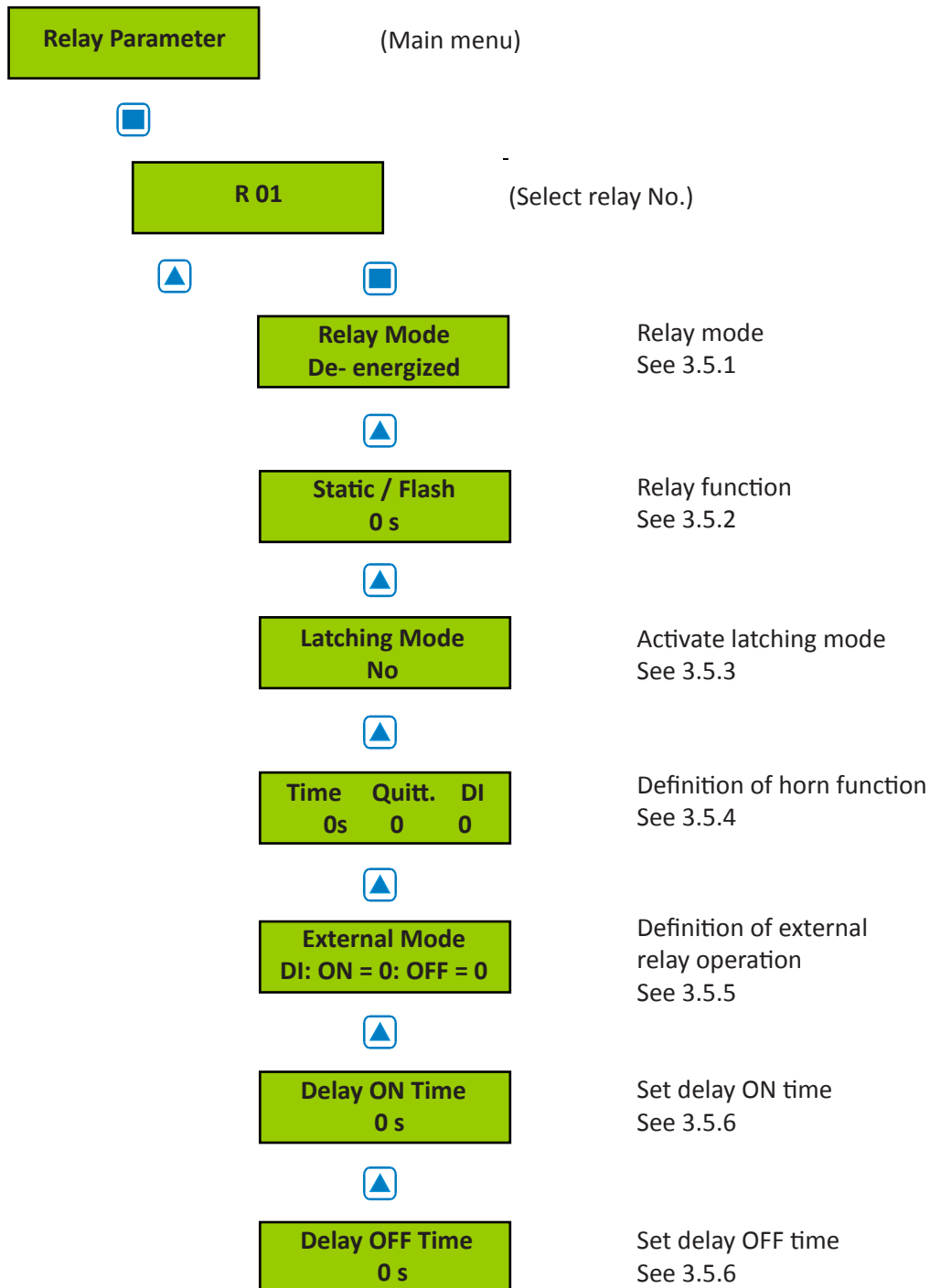

3.5.1 Relay Mode

Definition of relay mode:

Symbol	Description	Setting Status	Function
R 01	Relay No.		Selection of relay
De-energized	Relay Mode	De- energized	De-energized = Alarm ON = Relay ON Energized = Alarm ON = Relay OFF

3.5.2 Relay Function Static / Flash

Definition of relay function

Symbol	Description	Setting Status	Function
R 01	Relay No.		Selection of relay
0	Function	0	0 = Relay function static > 0 = Relay function flashing (= Time period in sec.) Impulse / Break = 1:1

3.5.3 Latching Mode

Definition of latching function

Symbol	Description	Setting Status	Function
R 01	Relay No.		Selection of relay
No	Latching Mode	No	No = Latching mode non active Yes = Latching mode active

Acknowledging a latching relay in the menu "Status Relay" is only possible if the gas concentration is again lower than the alarm threshold including hysteresis. In this case the status latching occurs in the display.

Example: Alarm relay R2 with latching mode

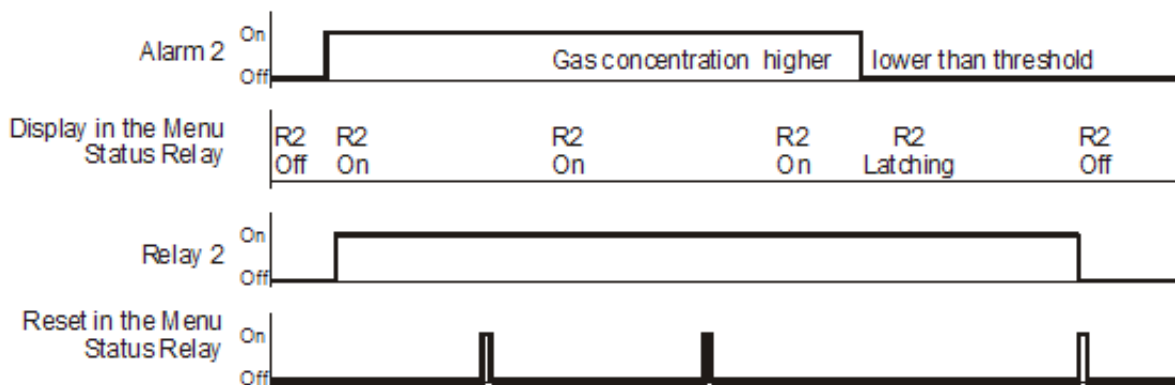

3.5.4 Horn Function

The internal horn is connected to alarm relay R3 (open collector).

This alarm output is defined as horn relay by this parameter with the following possibilities to reset.

- By pressing any of the 4 push-buttons (only possible in the starting menu).
- Automatic reset at the end of the fixed time.
- By an external push-button (assignment of the digital input).

The horn function is only activated if at least one of the two parameters (time or digital input) is set.

Special function Response

After acknowledging the output (by push-button or externally) time starts. When this time has run out and the alarm is still acting, the relay is set again.

Symbol	Description	Setting Status	Function
R 03	Relay No.		Selection of relay
Quit	Mode	0	0 = Reset of the relay after time having run out, or by push-button 1 = Reset of the relay by push-button, after time having run out and when alarm is still acting, relay is set again. (Response function).
Time		120	Time for automatic reset function or response function 0 = no reset function
DI		0	Assignment, which digital input resets the output.

Acknowledge the horn output

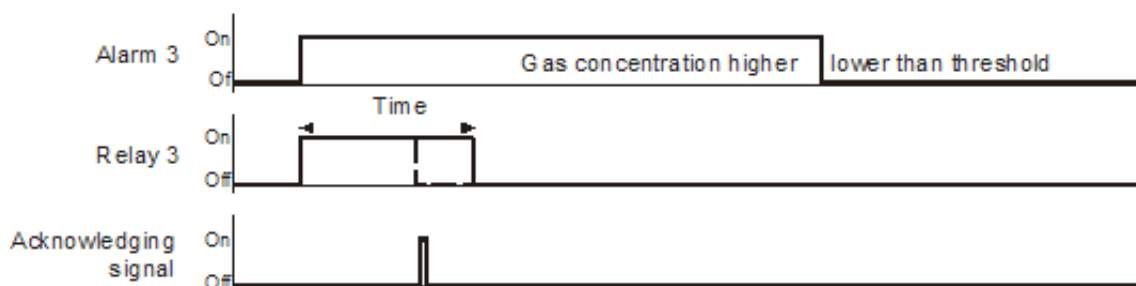

Special function „Response“. (Return of the horn relay)

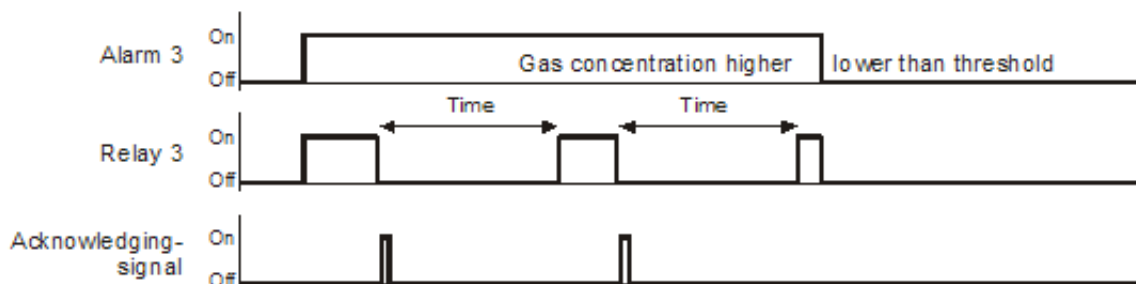

3.5.5 External Relay Operation

Assignment of the digital input (DI) for external switching of the alarm relay (ON and/or OFF). This function has priority to gas alarm and/or manual switching in the menu "Status Relay".

Symbol	Description	Setting Status	Function
R 01	Relay No.		Relay Selection
DI-ON	External On	0	If digital input closed, relay switches ON
DI-OFF	External Off	0	If digital input closed, relay switches OFF

3.5.6 Delay Mode of the Relay.

Delay time ON starts when the alarm is released and/or delay time OFF starts when the alarm returns to normal condition.

Symbol	Description	Setting Status	Function
R 01	Relay No.		Relay Selection
0 s	Delay Time ON	0	Mode ON: Relay is only activated at the end of the defined time (sec.) 0 sec. = No delay
0 s	Delay Time OFF	0	Mode OFF: Relay is only deactivated at the end of the defined time (sec.) 0 sec. = No delay

3.6 Menu MP Parameters

Display and change of parameters, assignment of alarms to alarm relays and activation of Measuring Points (MP).

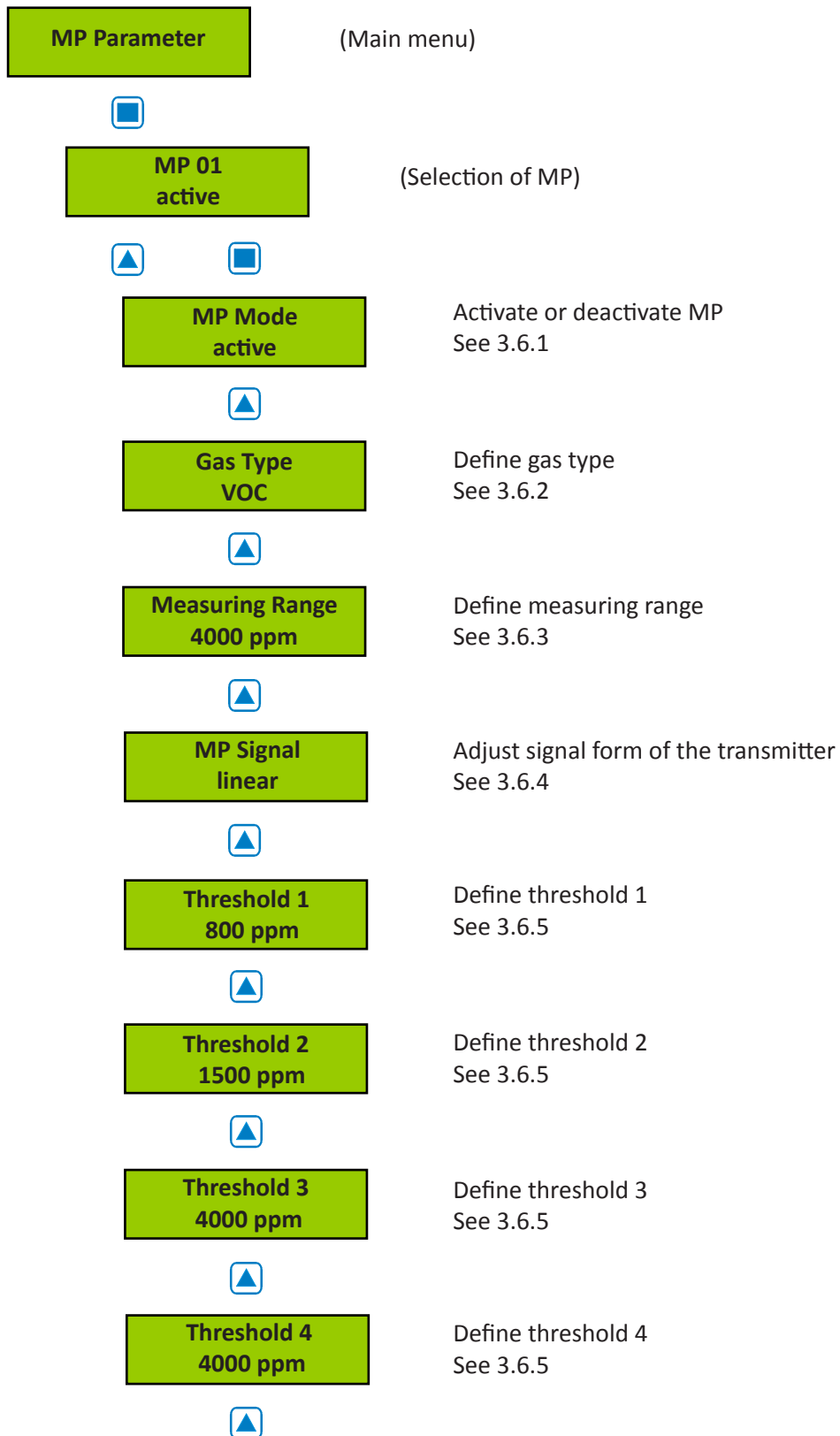

Hysteresis 200 ppm	Hysteresis See 3.6.5
Delay ON Time 0 s	Set delay time ON See 3.6.6
Delay OFF Time 0 s	Set delay time OFF See 3.6.6
C/A Mode CV	Define control mode See 3.6.7
Alarm - 1 2 3 4 Fault - 0 0 0 0	Assign MP fault to alarm See 3.6.8
A1; A2; A3; A4 01; 02; 03; 04	Assign alarm to alarm relay See 3.6.9
Analog Output 0	Assign MP signal to analog output See 3.6.10

3.6.1 Activate - Deactivate MP

Symbol	Description	Setting Status	Function
MP 01*	Measuring point		Selection MP No.
Active	MP Status	Not active	Active = Measuring point activated at the gas leak unit Not active = Measuring point not activated at the gas leak unit

*MP01 = On Board sensor

*MP02 = External Transmitter (optional)



3.6.2 Selection Gas Type

Assign gas type to attached gas transmitters.

Symbol	Description	Setting Status	Gas type		Unit	Measuring range ¹
MP 01	Measuring point					
O ₂	Gas type	O ₂	CO	Carbon monoxide	ppm	0 – 300
			O ₂ >	Oxygen (increasing) ²	Vol%	0 – 25
			O ₃	Ozone	ppm	0 – 5
			TOX	Toxic gas	ppm	0 – XX
			CO ₂	Carbon dioxide ⁴	ppk	0 – 50
			RH	Humidity	% RH.	0 – 100
			Temp.	Temperature	° C	0 – 50
			R22	Refrigerant gas	ppm	0 – 2000
			R134	Refrigerant gas	ppm	0 – 300
			R123	Refrigerant gas	ppm	0 – 300
			R11	Refrigerant gas	ppm	0 – 300
			R411	Refrigerant gas	ppm	0 – 300
			R410	Refrigerant gas	ppm	0 – 300
			R407	Refrigerant gas	ppm	0 – 300
			R416	Refrigerant gas	ppm	0 – 300
			R404	Refrigerant gas	ppm	0 – 300
			R409	Refrigerant gas	ppm	0 – 2000
			R408	Refrigerant gas	ppm	0 – 2000
			R402	Refrigerant gas	ppm	0 – 2000
			R401	Refrigerant gas	ppm	0 – 2000
			VOC	Air quality	ppm	0 – 2000
			ETC	Ethylene oxide	ppm	0 – 20
			Cl ₂	Chlorine	ppm	0 – 100
			H ₂ S	Hydrogen sulphide	ppm	0 - 50/100/200
			SO ₂	Sulphur dioxide	ppm	0 – 100
			Ex	Carbon dioxide ⁵	ppm	0 – 2000
			O ₂ <	Oxygen (falling) ³	Vol%	0 – 25
			NH ₃	Ammonia	ppm	0 – 300
			NO ₂	Nitrogen dioxide	ppm	0 – 25
			NO	Nitrogen oxide	ppm	0 – 50
			Ex	Combustible gas	%LEL	0 – 100

¹ Recommendation without obligation

² Oxygen measurements: Alarm at increasing concentration

³ Oxygen measurements: Alarm at falling concentration

⁴ Carbon dioxide measurements with unit ppk (1 vol% = 10 ppk)

⁵ Carbon dioxide measurements with unit ppm (1 vol% = 10.000 ppm)

3.6.3 Measuring Range

The measuring range can be defined arbitrarily between 10 and 10000. The measuring ranges in the table gas type are only recommendations without obligation.

The measuring range for MP01 (on-board gas sensor) is factory set, the measuring range for MP02 must agree with the signal (4 to 20 mA / (0)2 to 10 V) of the attached gas transmitter.

(4 mA / (0)2 V = Display 0 (ppm); 20 mA / 10 V = Display of the ultimate value of the measuring range)

3.6.4 MP Signal

Gas transmitters using electro-chemical or catalytic beat gas sensors normally produce a linear 4 to 20 mA / (0)2 to 10 V signal, proportional to the gas concentration.

Semiconductor gas sensors produce a non-linear (exponential) signal. This signal leads to a non-linear 4 to 20 mA / (0)2 to 10 V signal of the gas transmitter.

The Gas Leak Unit, VOC, is prepared for gas transmitters with linear signal as well as for µGard analog transmitters with semiconductor sensor and non-linear signal. The classification of signals is defined in this menu.

Symbol	Description	Setting Status	Function
MP 01	Measuring Point		Selection of MP No.
Linear	MP Signal	Linear	Linear = Transmitter with linear output signal Non-linear = Transmitter with non-linear output signal

3.6.5 Threshold / Hysteresis

For each measuring point four alarm thresholds are available for free definition. If the gas concentration is higher than the adjusted alarm threshold, the associated alarm is set. If the gas concentration falls below the alarm threshold inclusive hysteresis the alarm is again reset.

Unused alarm thresholds have to be defined at measuring range end point, in order to avoid false alarms.



For VOC measurement: Pay attention to the alarm activation at decreasing or increasing concentration!

Symbol	Description	Default Status		Function
MP 01	Measuring Point			Selection MP No.
40 ppm	Threshold	800 1500 4000 4000 200	Threshold 1 Threshold 2 Threshold 3 Threshold 4 Hysteresis	Gas concentration > Threshold 1 = Alarm 1 Gas concentration > Threshold 2 = Alarm 2 Gas concentration > Threshold 3 = Alarm 3 Gas concentration > Threshold 4 = Alarm 4 Gas concentration < (Threshold X –Hysteresis) = Alarm X OFF

3.6.6 Delay of Alarm ON or OFF

Definition of alarm ON and/or alarm OFF delay. The function applies to all alarms of an MP.

Symbol	Description	Default	Function
MP 01	Measuring Point		Selection of MP No.
0 s	Delay Time ON	0	Gas concentration > Threshold: Alarm is only activated at the end of the fixed time (sec.). 0 sec. = No Delay
0 s	Delay Time OFF	0	Gas concentration < Threshold: Alarm is only deactivated at the end of the fixed time (sec.). 0 sec. = No Delay

The delayed activation of an existing gas alarm can cause damage to persons and objects. The commissioning technician and/or the operator are solely responsible for the activation.

3.6.7 Control Mode

Definition of the alarm evaluation by means of current (CV) or average value (AV).

Symbol	Description	Default Status	Function
MP 01	Measuring Point		Selection MP No.
CV	Evaluation	CV	CV = Control by the current gas value AV = Control by the average gas value

Current- average value function see: 3.7.4

3.6.8 MP Fault Assigned to Alarm

Definition, which alarms are activated in case of a fault at the measuring point.

Symbol	Description	Default Status	Function
MP 01	Measuring Point		Selection MP No.
Alarm - 1234 Fault - 0000	Failure MP	0000	0 = Alarm not ON at MP failure 1 = Alarm ON at MP failure

3.6.9 Alarm Assigned to Alarm Relay

Each of the 4 alarms can be assigned to any alarm relay. Unused alarms are not assigned to any alarm relay.

Symbol	Description	Default Status	Function
MP 01	Measuring Point		Selection MP No.
1	A1 A2 A3 A4	01 02 03 00	01 = Alarm 1 activates alarm relay R 01 02 = Alarm 2 activates alarm relay R 02 03 = Alarm 3 activates alarm relay R 03 00 = Alarm 4 doesn't activate any alarm relay



3.6.10 MP Signal Assigned to Analog Output

The measuring point signal can be assigned to the analog output. At this the signal defined in the control mode (current or average value) is transmitted.

Analog output see also: 3.7.7

Symbol	Description	Default Status	Function
MP 01	Measuring Point		Selection MP No.
0	A	0	0 = MP Signal not assigned to analog output 1 = MP Signal assigned to analog output 1

3.7 Menu System Parameters

Displays and changes the system parameters of the Gas Leak Unit

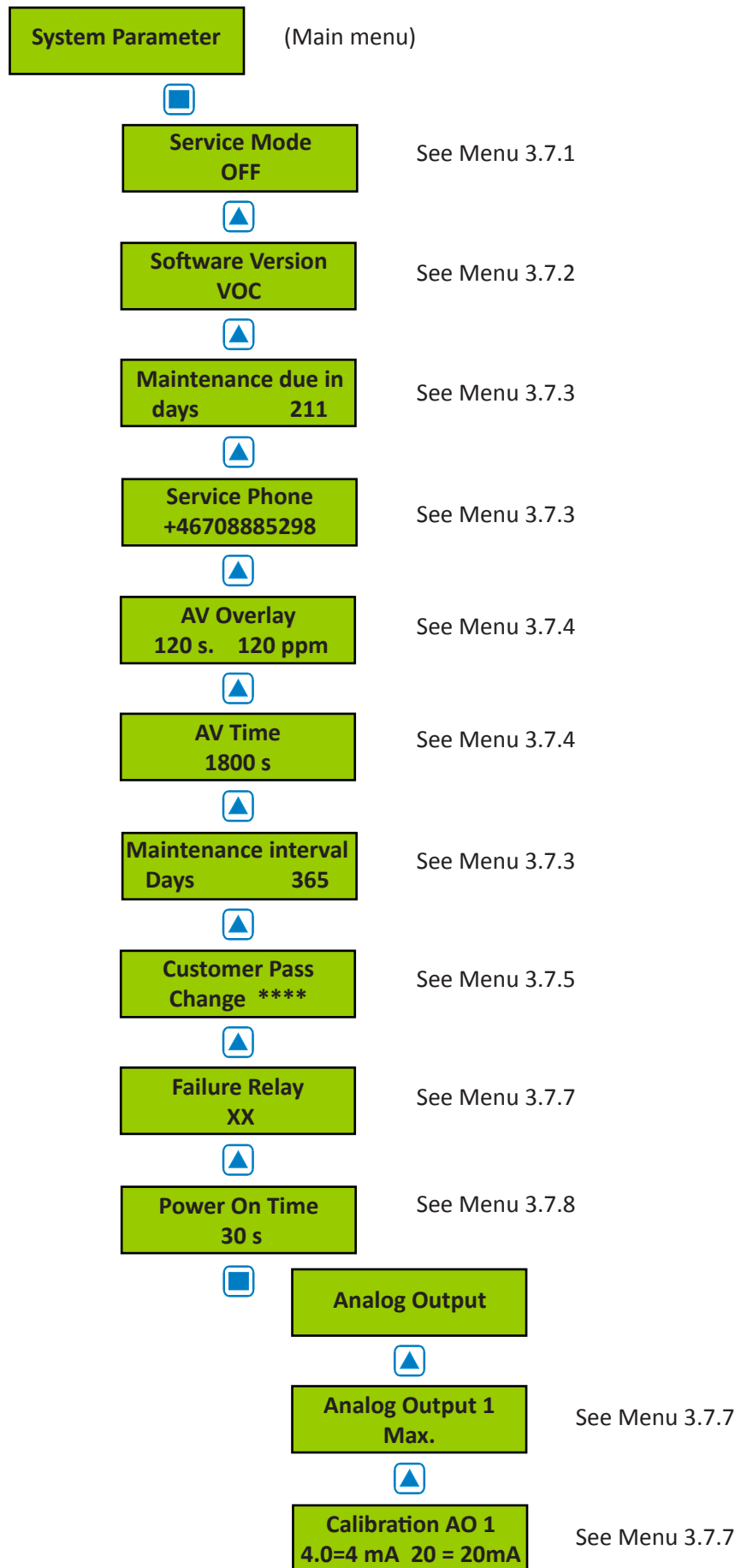



3.7.1 Service Mode

When the service mode is active (ON) the alarms are not transmitted to the alarm relays (in case of calibration or service work). The service mode is reset automatically after 60 minutes or manually in the menu "Service Mode".

Symbol	Description	Default Status	Function
Off	Service Mode		Off = Alarms activate the associated alarm relays On = Alarms are not transmitted to the alarm relays

3.7.2 Software version

Symbol	Description	Default Status	Function
SPC03-XX	Software Version		XX = Software Version

3.7.3 Maintenance Concept

Integrated in the VOC system there is a control of the maintenance intervals required by law or by the customer.

At commissioning or after maintenance the number of days until the next due maintenance is entered = Reset of the maintenance message (service phone no.). When the days counter reaches zero, the failure signal is activated the following morning at 9 o'clock, and the phone no. of the service technician occurs in the display.

The remaining days until the next maintenance can be read from the menu "Maintenance in".

The service phone no. can be entered individually in the next menu.

Symbol	Description	Default Status	Function
XXX	Maintenance in		Remaining days until the next maintenance
XXX	Maintenance interval	365	Reset of the maintenance message by entering the number of days until the next maintenance.
+460708885298	Phone No.		Input of the individual service phone no.

3.7.4 Average Function

For each active measuring point the Gas Leak Unit calculates the arithmetic average value out of 10 measurements got within the time unit defined in the menu "AV Time". This average value is indicated in the menu "Measuring Values" next to the current value. At each measuring point the control mode (current or average value) is defined for the alarm evaluation.

The alarm evaluation of the control mode average value is overlaid by the current value, when the current value exceeds the alarm threshold defined in the menu "AV Overlay". The overlay is delayed by the time factor defined in this menu. With time factor 0 sec. the overlay is not active

Symbol	Description	Default Status	Function
120 s 120 ppm	AV Overlay	120 s 120 ppm	sec. = Delay time of average value overlay. 0 = No overlay function ppm = Alarm threshold of average overlay
1800 s	AV Time	1800 s	sec. = Time for the calculation of the average value

3.7.5 Customer Password (Code 4)

Change the system password for level 4

Symbol	Description	Default Status	Function
XXXX	Customer Password		XXXX = Definition of an individual 4-digit customer's password (level 4)

3.7.6 Analog Output

The Gas Leak Unit has one analog output (AO01) with (0)4 to 20 mA / (0)2 to 10 V signal. The signal of MP01 or/and MP02 can be assigned to the analog output. The assignment is effected in the menu "MP Parameters" for each MP. The measuring point sends the signal, which is defined in the menu "C/A Mode".

The output signal (mA / V) and starting point (0 / 20%) is selected at the I/O Board by means of jumper. See fig. 5.

Out of the signals of all assigned measuring points the Gas Leak Unit determines the minimum, the maximum or the average value and transmits it to the analog output. The definition, which value is transmitted, is effected in the menu "Analog Output 1".

The analog output can be calibrated at 4 and at 20 mA, only in mA mode. Therefore an ampere meter (measuring range 25 mA) can be attached to the AO and the respective factor has to be changed until the analog output corresponds to 4 and/or 20 mA. During calibration evaluation of the measuring point signals is not possible. This calibration is effected by the factory. The factors shall not be changed.

Symbol	Description	Default Status	Function
Max.	Select Output Mode	Max.	Min. = Displays the minimum value of all assigned MP Max. = Displays the maximum value of all assigned MP Average = Displays the average value of all assigned MP
4.0 20.0	Calibration	4.0 20.0	4. = Calibration factor at 4 mA 20.0 = Calibration factor at 20 mA

3.7.7 Define the Failure Relay

Definition of the failure relay. See also fault management (3.1)

Symbol	Description	Default Status	Function
X	Fault Relay	RX	RX = Define the fault relay

3.7.8 Power On Time

Gas sensors need a running-in period, until the chemical process of the sensor reaches stable conditions. During this running-in period the current signal can lead to an unwanted releasing of a pseudo alarm. Therefore the power on time is started at the VOC after having switched on the power supply. While this time is running out, the Gas Controller does not activate any alarms. The power on status occurs in the starting menu.

Symbol	Description	Default Status	Function
30 s	Power On Time	30 s	XX = Define the power on time (sec.)

4 Mounting / Electrical Connection

The Gas Leak Unit is fixed to the wall through the mounting holes at the 4 corners of the housing. These mounting holes are accessible after opening the housing. If you use the mounting holes at the bottom part of the housing, the device loses the protection class IP 65.

We recommend considering the following when choosing the mounting place:

- Mounting height: About 1.2 to 1.8 m (4 to 6 ft.) above floor
- Do not mount the transmitter next to doors, windows, air inlets and outlets.
- Free air supply must be granted.
- Vertical mounting (air inlet at the transmitter down/up.
- Avoid direct sunlight
- Customer's instructions.

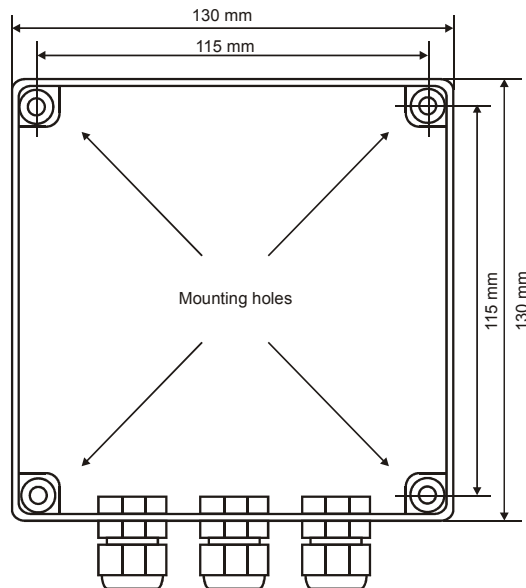
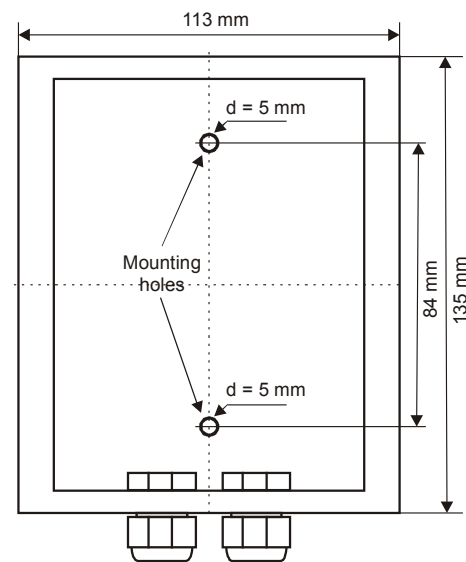

Fig. 01 Standard plastic housing



Stainless steel housing

4.1 Electrical Connection

The technical requirements and regulations for wiring, electrical security, as well as project specific and environmental conditions etc. must be observed when mounting.

The electrical installation may only be completed by a qualified electrician in full compliance with pertinent regulations.

We recommend the following cable types¹

- Power supply J-Y(St)Y 2x2 x 0,8
- Alarm relay J-Y(St)Y 2x2 x 0,8
- Gas transmitter J-Y(St)Y 2x2 x 0,8

¹ The recommendation does not consider local conditions such as fire protection etc.

For the exact position of the terminals see the following connection diagram.

When choosing the option "Power Supply" you have to make sure that a switch or a circuit breaker is provided in the building automation especially for the VOC. It must be installed easily accessible near the VOC. It has to be marked as a disconnecting device for the VOC. This switch or circuit breaker shall meet the relevant requirements of IEC 60947-1 and IEC 60947-3.

4.2 Connection Diagram

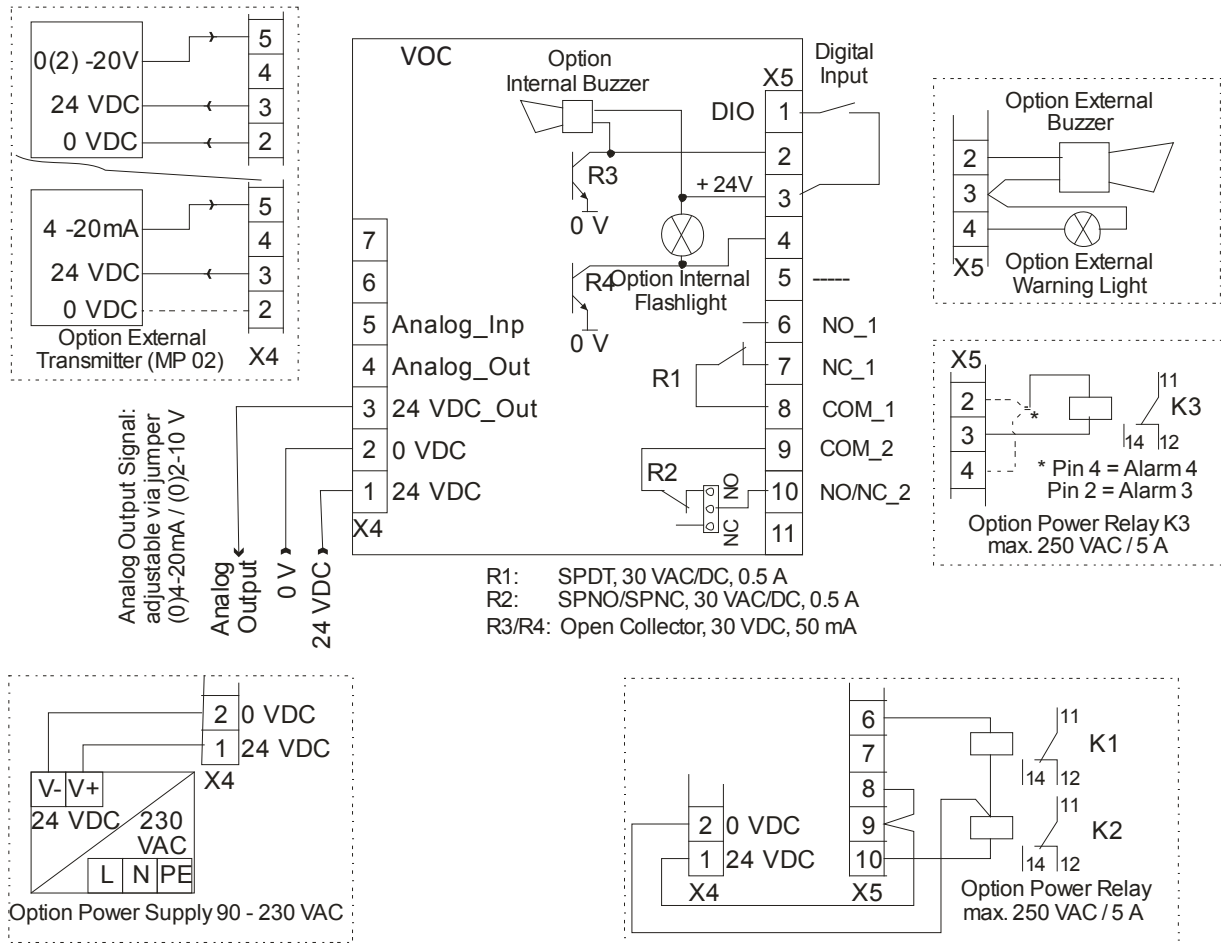

Fig. 2 Connection diagram

* The analog input function is determined by the hardware. Each PCB has got a label with the specific type. See fig. 4.

4.3 Connector Block / Overview VOC Module

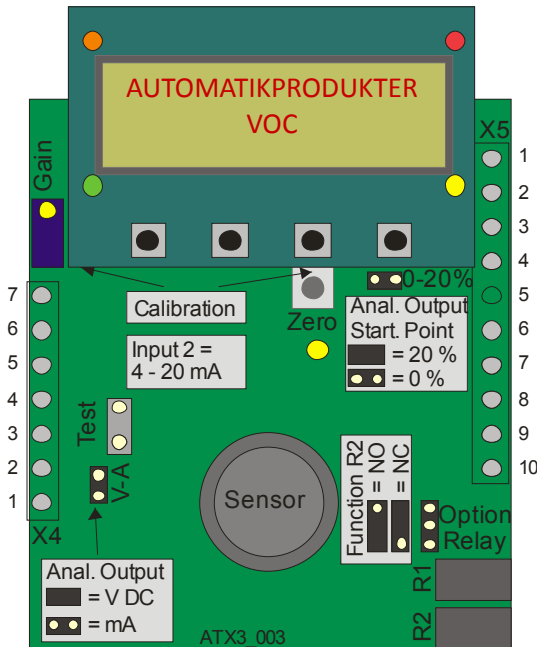

Fig. 3 PCB

Jumper 0- 20 %	Jumper V-A	Output signal
Not set	Not set	0 – 20 mA
Set	Not set	4 – 20 mA
Not set	Set	0 – 10 V
Set	Set	2 – 10 V

Fig. 4 Selection Output Signal

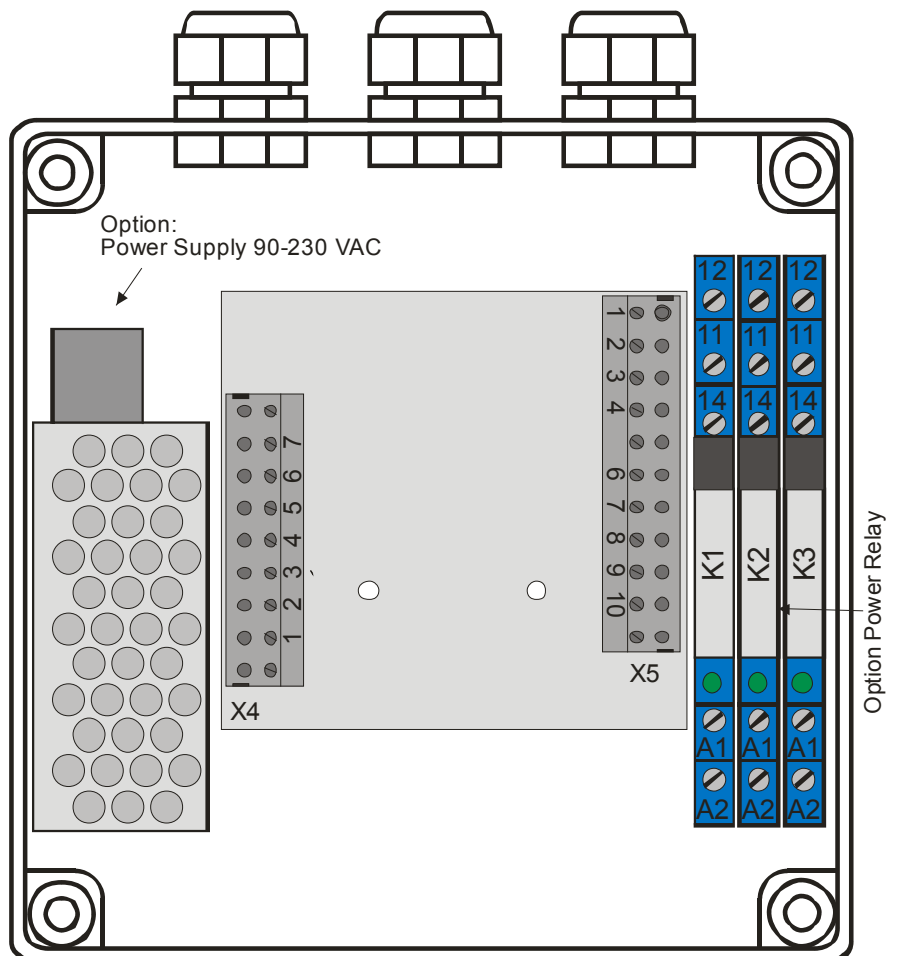

Fig. 5 Housing

5 Commissioning

5.1 Commissioning

Prior to commissioning, the wiring of the VOC including all field devices must be completely terminated!

Check the optional external transmitter input signal (current or voltage signal). It has to be the same as indicated on the label of the PCB. See fig. 3.

Select the contact for relay 2 with jumper NC/NO. See fig. 2 and 3.

Select the analog output signal with jumper V-A and 0-20%. See fig. 3 and 4.

After switching the power supply "ON" and at the end of the Power ON Time, the VOC is ready for use.

The VOC is delivered with standard parameters and set points for the on-board sensor (MP 01). These parameters have to be checked at commissioning and adjusted if necessary. If an additional external transmitter is connected, then you have to set the parameters for MP02 according to the intended application.

The standard parameters can be taken from the following configuration and parameter card. We recommend registering the individual parameters and set points into the list.

We recommend checking the parameters and set points according to the following check list.

5.2 Checklist Commissioning

System Parameter

Parameter	Finished
Parameter of average function	
Password level 1 (customer's password)	
Function analog output	
Define fault relay	
Power ON time	
Service phone no.	
Maintenance date	

Relay Parameter

Parameter	Finished			
	Relay R 1	2	3	4
Relay mode				
Function static / flash				
Latching mode				
Horn function				
External relay operation				
Delay ON time				
Delay OFF time				

MP Parameter

Parameter	Finished	
	MP No. ¹ 1	2
MP mode		
Gas type		
Measuring range		
MP signal		
Threshold 1		
Threshold 2		
Threshold 3		
Threshold 4		
Hysteresis		
Delay ON time		
Delay OFF time		
C/A mode		
Assigned failure <> alarm		
Assigned alarm <> alarm relay		
Assig. MP sig. <> analog output		

¹ MP 01 = On Board Sensor, MP 02 = external Transmitter



6 Configuration and Parameter

Commission:		Project No	
Customer:			
Commissioning - Company			
Commissioning - Date		Service Technician	

6.1 Configuration Card of System Parameters

Service	Software Version	Maintenance due in x days	Service Phone	AV Overlay			Maintenance interval	Customer Pass	Fault Relay	Power ON Time
Default	SPC 03	211	+46708 885298	ppm	Time	AV Time	365	1234	0	30 s

Analog Output 1		
	Calibration	
Mode	= 4	= 20
Max.	4.0	20.0

6.2 Configuration Card of Alarm Relays

Relay No.	Mode	Static Flash	Latching Mode	Horn Function			External		Delay Time	
				Time	Quitt	DI	ON	OFF	ON	OFF
Default	Energized	0 s	No	0	0	0	0	0	0	0
R01										
R02										
R03										
R04										



6.3 Configuration Card of Measuring Parameters

MP No.	MP Status	Gas Type	Measuring Range	MP Signal	Thresholds				Hyst
					A1	A2	A3	A4	
Default	Not active	VOC	200	Linear	800	1500	4000	4000	200
01									
02									

Delay Time (sec.)		CV/AV	Assigned MP Fault <> Alarm				Assigned Alarm <> Alarm Relay				AO
ON	OFF		A1	A2	A3	A4	A1	A2	A3	A4	
0	0	CV	1	1	0	0	R1	R2	R3	R4	0



7 Specifications

Electrical	
Power supply	18 – 28 VDC/AC, reverse polarity protected
Power consumption (without options)	100 mA, max. 2,5 VA
Analog output signal, (0 - 4000 ppm) Selectable: Current / Voltage : Starting point 0 or 20%	(0) 4 – 20 mA, load \leq 500 Ω (0) 2 – 10 V, load \geq 50 k Ω Proportional, overload and short-circuit-proof
Alarm relay (R1)	30 VAC/DC, 0.5 A, potential-free, SPDT
Alarm relay (R2)	30 VAC/DC, 0.5 A, potential-free, SPNO/SPNC
Binary output (R3; R4)	30 VDC, 0,05 A open collector output
Visualization	
Display	Two lines, each 16 characters
Status LED (4)	Normal operation- Fault- Alarm 1- Alarm 2
Operation	4 push- buttons, menu-driven
Operation Environment	
Humidity	15 – 90 % RH non condensing
Working temperature	- 10° C to + 50° C (14 °F to 122 °F)
Storage temperature	5° C to + 30° C (41 °F to 86 °F)
Pressure range	Atmospheric \pm 10 %
Physical	
Enclosure, plastic version type C	Polycarbonate
Combustion	UL 94 V2
Colour	RAL 7032 (light grey)
Dimensions (W x H x D)	130 x 130 x 75 mm (5.12 x 5.12 x 2.95 in.)
Weight	Approx. 0,6 kg (1.32 lbs.)
Protection class	IP 65
Installation	Wall mounting
Cable entry	Standard 3 x M 20
Wire connection	Screw type terminals min 0.25 to 2.5 mm ² (14 to 30 AWG)
Guidlines	EMC Guidelines 2004/108//EEC Low voltage guideline 73/23/EEC; CE
Warranty	1 year on material (without sensor)



Analog input (external transmitter)	
Analog input (1)	4 – 20 mA, input resistance 200 Ω, (0) 2 – 10V, input resistance 25 kΩ, overload- and short-circuit-proof
Power supply for external analog transmitter	24 VDC max. 50 mA
Buzzer	
Acoustic pressure	85 dB (A) (distance 300 mm) (1 ft.)
Frequency	3500 Hz
LED flashlight red	
Flashing frequency	Adjustable
Luminosity	> 5.000 mcd
Power supply 90 - 230 VAC	
Consumption max.	25 VA
Power Relay (K1 – K3)	
Switch capacity	250 VAC, 5 A, potential-free, SPDT
Serial Interface	
Transceiver	RS 485 / 19200 Baud
Heating	
Temperature controlled	3 ± 2 °C (38 °F ± 3.6 °F)
Ambient temperature	-40 °C (-40 °F)
Power consumption	0.3 A; 7.5 VA
Duct mounting version	
Flow speed	5000 - 20.000 m/h (3 to 12 miles/h)
Duct diameter	ca. 200 – 1000 mm (8 – 40 inch.)

8 Gas Sensor

8.1 Description

The semi-conducting metal oxide sensor measures the electrical conductivity of the nanocrystalline metal oxide coated on a heatable substrate. The typical operating temperature is between 300 and 400 °C. The doping of the metal oxide with noble metals results in a positive sensibility to combustible gases like VOCs, carbon monoxide and natural gas.

The doping permits the adaptation to the demands of the measuring task. VOCs are partially or totally burnt at the sensor surface by the oxygen of the metal oxide. The electrons released in the semi-conductor by this process lead to an increase of the electrical conductivity.

At the end of the combustion process, the metal oxide returns to its initial state by incorporating oxygen from the air, with the conductivity also adopting the initial value. The change of the conductivity is evaluated via the internal micro-controller and output as a standard signal.

8.2 VOC Measurements

The VOC content in indoor areas is mainly determined by the persons present and their activities. See table 1. When for example working with cleaning agents or when cooking, VOCs (Volatile Organic Compounds) are set free, but also human respiration is a constant source of volatile metabolism products (VOCs).

The air quality sensor detects the increasing VOC level and calculates the proportional CO₂ value. The VOC/CO₂ correlation was determined by taking measurements under real conditions. See diagram 1.

To this day, there aren't any standard signals for the VOCs; therefore the IAQ air quality sensor reduces the measured VOC values to CO₂ equivalents with the unit ppm. This grants the compatibility to existing CO₂ ventilation standards.

Each time the IAQ air quality transmitter is switched on, it runs through a warm-up period of 20 minutes. During this warm-up period there aren't any measurements; the sensor outputs the signal of 80% of the measuring range. After the warm-up period, the sensor interprets the currently read VOC value as zero-point, independently from the actual concentration. An internal algorithm continuously updates the zero-point by taking the lowest measured VOC value. Therefore the ambient air should be of low VOC content after the warm-up period. This can be obtained by shortly venting when starting the measurements with the 80% signal.

If the sensor isn't started at low VOC concentrations, it can take a couple of days until the internal algorithm has updated the zero-point so far that effective measuring results are available.

The natural sensor drift and ageing is corrected by the implemented control algorithms.

Indoor Air		Typical Substances		Ventilation
Contamination Source	Emission Source	VOCs	Others	
Human Being	*Breath	Acetone, Ethanol, Isoprene		Demand controlled
	*Skin respiration & transpiration	CO ₂		
	*Flatus	Methane, Hydrogen		
	*Cosmetics	Limonene, Eucalyptol		
	*Household Supplies	Alcohols, Esters, Limonene		
	*Combustion (Engines, Appliances, Tobacco Smoke)	Unburnt Hydrocarbons		
*Building Material *Furniture *Office Equipment +Consumer Products	*Paints *Adhesives *Solvents *Carpets	Formaldehyde, Alkanes, Alcohols, Aldehydes, Ketones, Siloxanes		Permanent (5-10%)
	*PVC	Toluene, Xylene, Decane		
	*Printers/Copiers, Computers	Benzene, Styrene, Phenole		
		CO CO ₂ Humidity		

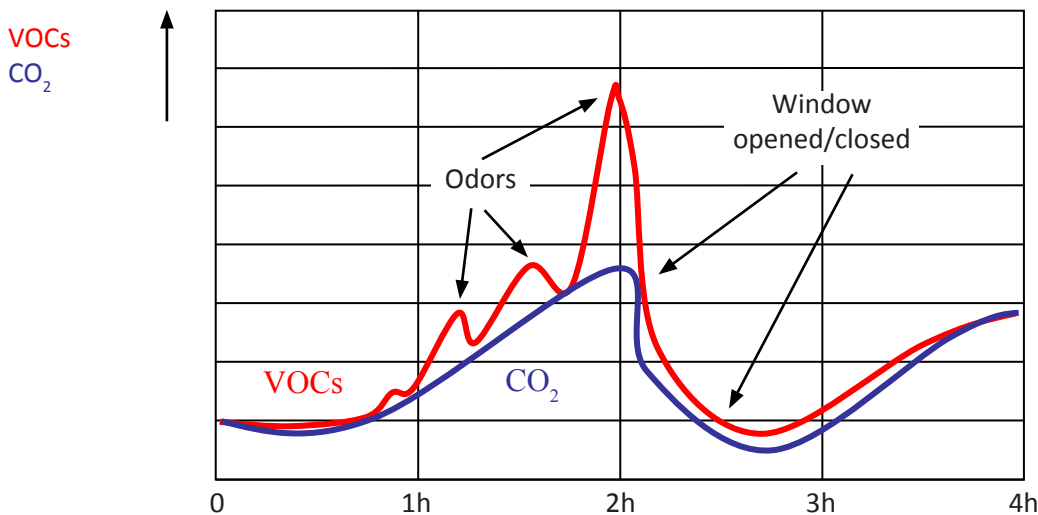

Diagram 1: Correlation CO₂- VOC (records from a business meeting session)

9 Commissioning

Consider commissioning instructions at any exchange of the sensor element as well. Only trained technicians should perform the following:

- Check mounting location.
- Select output signal form: Current or voltage, and starting point 0 or 20%. See fig.5.
- Check power voltage.
- Check PCB SM03-002 for correct mounting at X4 and X5



10 Inspection and Service

Inspection, service and calibration of the VOC should be done by trained technicians and executed at regular intervals. We therefore recommend concluding a service contract with Automatikprodukter or one of their authorized partners.

According to EN 45544-4, inspection and service has to be executed at regular intervals. The maximum intervals have to be determined by the person responsible for the gas warning system according to the legal requirements.

AP recommends checking the Transmitter every three months and maintaining it every 12 months. If different intervals are indicated, always consider the shortest interval.

Inspections and services must be documented. The date for the next maintenance has to be affixed to the transmitter.

10.1 Inspection

The Gas Leak Unit should be controlled regularly by a competent person according to EN 45544-4. The following has to be checked in particular:

- Maintenance/ calibration interval not exceeded.
- Visual inspection of the transmitter including cable for damage etc.
- Remove dust deposits, especially at the gas inlet.
- The filter at the gas inlet has to be replaced if extremely dirty.
- Check the function of alarm relays.

10.2 Exchange of Sensor Element

Please send the complete PCB back to the manufacturer for exchange of the sensor.

11 Specification Gas Sensor

Sensor performances	
Gas type	* VOC (alcohols, aldehydes, aliphatic hydrocarbons, amines, aromatic hydrocarbons, carbon monoxides, methane, LPG, ketones and organic acids)
Sensor element	Metal oxide semi-conductor
Measuring range	450 – 4000 ppm VOC or 450 - 2000 ppm
Accuracy	± 150 ppm
Repeatability	± 5 % of reading
Response time	t ₉₀ < 60 sec.
Warm-up time	20 min
Sensor life expectancy	> 10 years/normal ambient conditions
Humidity range – short-term	15 – 95 % RH non condensing
Temperature range - continuous	0° C to + 50 °C (32 °F to 122 °F)
Temperature range - short-term	0° C to + 50 °C (32 °F to 122 °F)
Pressure range	Atmospheric ± 10%



12. Levels to set in the ventilation system

[ppm]	Air Quality
2100	BAD Heavily contaminated indoor air Ventilation required
2000	
1900	
1800	
1700	
1600	
1500	MEDIOCRE Contaminated indoor air Ventilation recommended
1400	
1300	
1200	
1100	
1000	FAIR
900	
800	GOOD
700	
600	EXCELLENT
500	
400	

Measurement starts at 450 ppm. At 10 volt output signal it becomes approximately 11% at 4800 ppm and 22% at 0 to 2000 ppm.



13 Part Disposal

Since August 2005 there are EC-wide directives defined in the EC Directive 2002/96/EC and in national codes concerning the waste electrical and electronic equipment and also regarding this device.

For private households there are special collecting and recycling possibilities. For this device isn't registered for the use in private households, it mustn't be disposed this way. You can send it back to your national sales organisation for disposal. If there are any questions concerning disposal please contact your national sales organisation. Outside the EC, you have to consider the corresponding directives.

14 Notes and General Information

It is important to read this User Manual carefully in order to understand the information and instructions. The SPC-X3 gas monitoring, control and alarm system may only be used for applications in accordance to the intended use. The appropriate operating and maintenance instructions and recommendations must be followed.

Due to permanent product developments, Automatikprodukter reserves the right to change specifications without notice. The information contained herein is based on data considered to be accurate. However, no guarantee or warranty is expressed or implied concerning the accuracy of these data.

14.1 Intended Product Application

SPC is designed and manufactured for controlling, for saving energy and keeping OSHA air quality in commercial buildings and manufacturing plants (i.e. detection and automatic exhaust fan control for automotive maintenance facilities, enclosed parking garages, engine repair shops, warehouses with forklifts, fire stations, tunnels, etc.).

14.2 Installers' Responsibilities

It is the installer's responsibility to ensure that all SPC units are installed in compliance with all national and local regulations and OSHA requirements. All installations shall be executed only by technicians familiar with proper installation techniques and with codes, standards and proper safety procedures for control installations and the latest edition of the National Electrical Code (ANSI/NFPA70). It is also essential to follow strictly all instructions as provided in the User Manual.

14.3 Maintenance

We recommended checking the SPC-X3 system regularly. Due to regular maintenance differences in efficiency can easily be corrected. Limited Warranty Re-calibration and part replacement may be implemented in the field by a qualified technician and with the appropriate tools. Alternatively, the easily removable plug-in transmitter card with the sensor may be returned for service to Automatikprodukter.

14.4 Limited Warranty

Automatikprodukter warrants the SPC against defects in material or workmanship for a period of one (1) year beginning from the date of shipment. Should any evidence of defects in material or workmanship occur during the warranty period, Automatikprodukter will repair or replace the product at their own discretion, without charge.

This warranty does not apply to units that have been altered, had attempted repair, or been subjected to abuse, accidental or otherwise. The above warranty is in lieu of all other express warranties, obligations or liabilities.

This warranty applies only to the SPC-X3. Automatikprodukter shall not be liable for any incidental or consequential damages arising out of or related to the use of the SPC.