

the EXTENSION

A Technical Supplement to control NETWORK

TEN RECOMMENDATIONS WHEN IMPLEMENTING EIA-485 NETWORKS

1. Recognize that EIA-485 is only a physical layer standard and connectivity between two machines each with an EIA-485 interface is not ensured.
2. Since EIA-485 is basically a specification for driver, receiver and transceiver chips, the manufacturer of the equipment needs to specify cabling, grounding, termination, fail-safe bias and connectors.
3. Data rate and segment lengths are not addressed in the standard and, therefore, must be specified by the manufacturer. A high-speed EIA-485 design could be quite different from a low speed design.
4. EIA-485 is intended to be cabled as a linear bus with daisy-chain connections. Stubs may or may not be allowed. Do not cable in a star topology.
5. Carefully review grounding practice. EIA-485 transceiver damage is usually due to excessive common mode voltage caused by unequal ground potentials at the various devices. Sometimes a third-wire ground connection must be carried to all nodes to ensure that the common mode voltage remain within limits.
6. Device protection circuitry can certainly minimize device failures, however, verify that high data rates can be maintained with protection applied.
7. Although optically isolated EIA-485 will not protect the transceivers themselves, it will provide a level of protection to the attached equipment. Be sure to run a common wire between all optically-isolated transceivers.
8. The design of EIA-485 repeaters is tricky. Use only those repeaters recommended by the manufacturer.
9. Be careful when applying termination and fail-safe bias so as to not introduce excessive loading. Termination is only applied at each end of the network while bias is applied per the manufacturer's recommendation.
10. EIA-485 can be quite an effective network as long as it is applied properly. Here are our recommendations:
 - If the devices are in the same control panel, use DC coupled EIA-485 and individual earth (chassis) connections for ground reference.
 - If the devices are in separate control panels within the same building use optically-coupled EIA-485 and a separate reference ground wire.
 - If the devices are in separate panels in different buildings, use fiber optics if at all possible.

EIA-485 networks are usually configured in a daisy-chain fashion with termination at each end.

Understanding EIA-485 Networks

INTRODUCTION

One of the more popular technologies for interconnecting devices on a network is EIA-485. Known throughout industry as RS-485, the proper title for the standard is TIA/EIA-485-A "Electrical Characteristics of Generators and Receivers for Use in Balanced Digital Multipoint Systems."¹ The EIA-485 standard is misunderstood to mean more than what it defines. According to the standard it specifies the characteristics of the generators and receivers used in a digital multipoint system. It does not specify other characteristics such as signal quality, timing, protocol, pin assignments, power supply voltages or operating temperature range. A multipoint system consists of two or more generators and one or more receivers. A generator is the same as a transmitter and since two or more transmitters can exist on the same electrical bus, EIA-485 is suitable for multimaster systems.

The standard itself is very short consisting of only 17 pages. Actually more guidance is available from its sister publication TSB89 "Application Guidelines for TIA/EIA-485-A."² An EIA-485 bus usually consists of two or more communication controllers each powered by a separate power source.

At a minimum, a single shielded or unshielded twisted-pair cable interconnects the various controllers in a daisy-chain fashion. In some instances a short stub is allowed; however, higher speed networks usually do not allow stubs. A star topology is definitely not recommended. Termination is usually applied to the ends of the network.

EIA-485 is basically a specification for the drivers, receivers and transceivers attached to the network. Therefore, parameters such as unit loads, output drive, short circuit current and common mode voltage are specified. Basically a driver must be able to source at least 1.5 volts differentially into 60 ohms (two 120 ohm terminators in parallel along with 32 unit loads) under a common mode voltage range of -7 to +12 Vdc. Data rates are not specified and there are a wide range of devices that conform to the standard but are intended either for high speed (up to 50 Mbps) or low speed (skew rate limited). So do not assume that all driver, receiver and transceiver chips are all the same. Some receivers and transceivers have higher input impedance thereby representing less than one unit load to the driver.

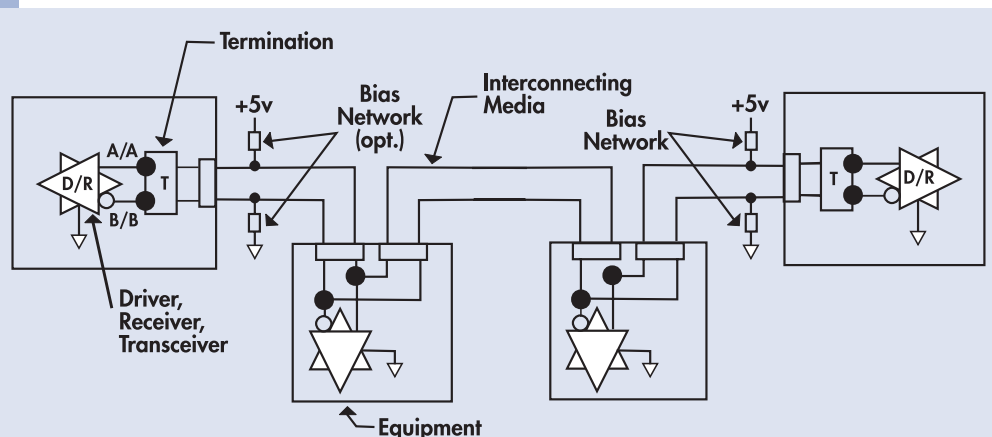

Physical Layer Standard

In terms of the Open Systems Interconnection Reference Model (OSI), EIA-485 only defines the lowest layer—the physical layer. It is used by Allen Bradley's DH-485,³ Profibus,⁴ BACnet's Master/Slave Token Passing option⁵ and ARCNET⁶ as well. Each of these implementations is different demonstrating that EIA-485 is not an all encompassing standard.

APPLICATION
PRESENTATION
SESSION
TRANSPORT
NETWORK
DATA LINK
PHYSICAL

In terms of the OSI model, EIA-485 only addresses the lowest layer.

There are several key topics that must be considered when deploying EIA-485 networks such as termination, fail-safe bias, connectors, grounding, cabling and repeaters.

TERMINATION

Terminating a data cable with a value equal to its characteristic impedance reduces reflections that could cause data errors. However, if the data rate is low or the cables are short, termination may be unnecessary. As data rates increase, termination becomes important. Since any device on the bus can transmit, it is probable that a node within the middle of the bus will transmit requiring that termination be applied to both ends of the bus segment. National Semiconductor offers a highly in-depth discussion on termination in application note AN-903⁷ and offers several alternatives. The most popular approach is DC termination although this approach results in higher power dissipation.

Resistive terminators typically have values of 120 to 130 ohms although twisted-pair cable impedances can be as low as 100 ohms. An 100 ohm terminating resistor is too low for the EIA-485 drivers. A value closely matching the cable impedance must be applied at some convenient location closest to the ends of the cable segment as possible. One possibility is to provide the resistor within a node

with a jumper to disable this option if termination is not required. The problem with this approach is that each node will be configured differently since only two nodes should have terminators. Care must be exercised to ensure that only the proper modules have termination invoked in order not to cause excessive bus loading.

Another approach is to use external termination outside the node. Profibus uses this approach. Both terminating and bias resistors are located in the shell of a DB9 connector. DIP switches within the shell are used to disable this feature. The advantage of this approach is that all nodes on the network are the same while connectors are used to properly configure the network.

Allen-Bradley's DH-485 uses a slightly different approach. Although terminating resistors are located within all nodes, an external jumper applied at the connector invokes termination. Again, this keeps the configuration in the connector and not within the node.

FAIL-SAFE BIAS

EIA-485 is a multipoint standard where individual devices transmit and receive data sharing a common two-wire medium. The opportunities for collisions (two transmitters on at the same time) are immense and a method of medium access control (MAC) is required. The 485 standard does not provide a bus arbitration scheme since this is not a requirement of the physical layer but is a requirement of the data link layer. With a master/slave protocol such as Profibus DP, bus arbitration with a single master and multiple slaves may not be a problem since the master directs all the traffic. Slaves are always listening and only respond to the master's request thereby avoiding collisions. During this time, the bus will "float" enabling noise to falsely trigger one of the bus receivers. This can occur because the receiver's output is undefined when the receiver's input voltage is less than 200 mv which could happen when the bus floats. To ensure that the bus assumes a defined state when all transmitters are off, fail-safe bias must be applied.

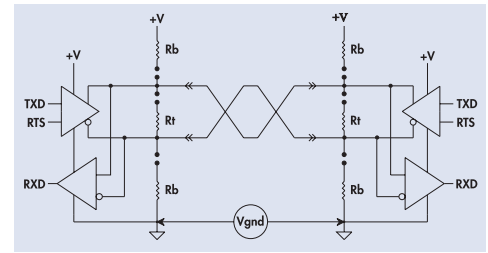

Disconnects are provided for fail-safe bias and termination.

National Semiconductor's AN-847⁸ application note fully discusses the need for fail-safe bias and recommends the proper biasing resistors needed to ensure that the bus differential voltage will not dip below 200 mv when idle. This note recommends a pull-up resistor to +5 volts attached to one signal line and a pull-down resistor to ground attached to the other. In conjunction with an end-of-line terminator, a voltage divider is created which impresses a bias across the line that exceeds 200 mv. Therefore, the receivers are biased in the "mark" (off, logic 1) state when the network is idle or when the transmitter sends a logic 1. When a transmitter sends a logic 0, the line will revert to "space" (on, logic 0).

Bias can be applied at any point on the bus segment but it is not necessary to lump the bias at only one point. The bias can be distributed throughout the segment with each node providing a portion of the bias. The advantage of this approach is that there is no need to provide an external bias network and power supplies. The problem with this approach is that the amount of bias developed depends upon the number of nodes on the bus. If too few nodes are connected, insufficient bias may result. Too much bias can result if too many nodes are connected causing excessive loading. If it is desired to supply lumped bias, a source for +5 volt power needs to be found which may be awkward to arrange. The other approach is to provide the complete bias requirement within each node while providing disconnecting jumpers on the node. In this way, only one node needs to be strapped for bias so record keeping must be good to ensure that the

location of this node is known when a replacement is necessary.

Profibus nodes source +5 volt power to the connector allowing for the bias resistors in the shell of the mating connectors. DIP switches within the shell disable the bias. Profibus uses 390 ohms for the pull-up and pull-down resistors and 150 ohms for termination. This provides about 800 mv of bias and a Thevenin equivalent termination resistance of 125 ohms. In TSB89 the resistance values are 620 and 130 ohms respectively which yields 475 mv of bias and a Thevenin equivalent termination resistance of 118 ohms. Either approach is adequate in terminating 120 ohm cable. However, it must be remembered that a termination resistor exists at the other end of the cable. The distant terminator will load the bias network thereby reducing the bias voltage by a factor of two. So instead of having 475 mv of bias, the resulting bias will be only 240 mv which is still above the 200 mv limit. This analysis assumes there is no resistance in the cable.

If the required bias is applied at two points, then cabling rules are simplified. Apply bias and termination only at the end two nodes by using a combination bias/termination resistor network.

There is another benefit to applying bias at end nodes. If a lumped bias was applied to one end of a long cable with termination at each end, a voltage divider is formed with the DC resistance of the cable. For 24 AWG cable, the resistance is 24 ohms/1000 ft. Since there are two wires in the cable, the cable resistance is effectively 48 ohms/1000 ft. An 2500 foot cable would have the same DC resistance as the end terminator thereby reducing the effective bias at the end node by a factor of two. This could put the distant nodes in an unreliable state compared to devices closer to the source of bias. A way of correcting this is to increase the cable wire gauge to reduce resistance or apply an equal amount of bias at the distant end of the cable effectively eliminating the voltage drop due to cable resistance.

CONNECTORS

With coaxial and fiber optic cabling, specifying connectors is easy since there is common practice in the industry. However, with twisted-pair cabling there are many options. Since the EIA-485 standard does not address connectors, trade associations or manufacturers must do so. From practice there seems to be three popular approaches. The traditional approach is to use a four-pin, six position RJ-11 or eight position RJ-45 providing plenty of pins for signal and ground reference. Some RJ style connectors are shielded.

Another approach to connectorization is to use removable open style screw connectors. DH-485 uses a six-position connector providing all the necessary connections including termination.

A popular connector is the DB9 connector that is used with the Profibus standard. With nine pins, it is easy to accommodate signals, logic ground, shield connection and power pins. DB9 housings are also available with metal shrouds for better EMC performance and the housing has built-in bias and termination provisions. This connector, however, tends to be pricey.

GROUNDING

Is EIA-485 a two wire or a three-wire system? It is most definitely a three-wire system. The standard clearly states that generators and receivers require a return path between circuit grounds at each end of a connection. This return path could be an actual wire in the cable connecting each of the logic grounds together or earth can provide the return path by having each logic ground returned to earth. Using the latter approach, a single pair twisted cable can be used. If the third wire is to be used, the standard states that the connection between logic ground and the third wire contain some resistance to limit circulating currents when other ground connections are provided for safety. This resistor could be between logic ground and frame (frame is tied to earth) or it can be between the logic ground and third connection. The standard uses 100 ohms as an example for both situations.

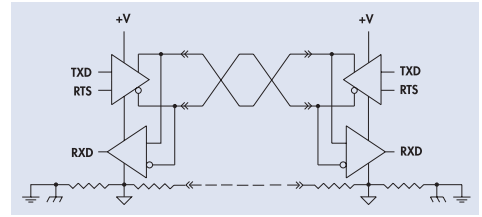

If a third wire connection is used, resistors must be used to limit circulating ground current.

There is much confusion and misunderstanding of the third wire requirement and difficulty in even finding a third wire. If the logic grounds of the transceivers are tied to earth and a third wire is used, there is almost a guarantee of a ground loop current which may or may not induce excessive noise that could disrupt data transmissions. The third wire will also be the path for fault currents which could be significant when the two ground potentials are different due to a significant electrical event. Still the third wire helps to ensure that the common mode requirements (-7 to +12 volts) of the transceivers are maintained. Excessive common mode voltage is the most common reason for transceiver failure.

Protection Circuitry

To protect EIA-485 transceivers from excessive common mode voltages, diode protection circuits are used which are referenced to earth or logic ground. Usually protection is provided from each data line to earth and it is necessary to protect against either a positive or negative occurrence which doubles the protection circuitry. The more robust the protection, the more the capacitance which limits the data rate.

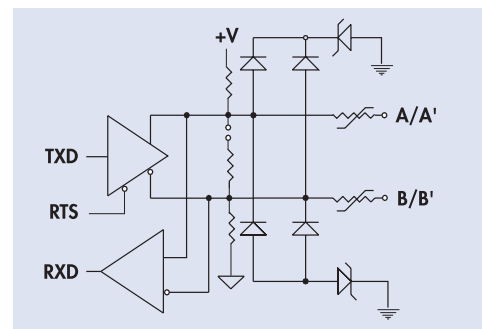

Protection circuitry is usually referenced to earth.

It is quite possible that systems will refuse to work at the desired data rate due to the increased capacitance. Some protection is afforded when the protection circuit consists of a bulky transient voltage suppressor in series with a diode. The capacitive divider created by the diode and suppressor in series yields a capacitance that is less than the diode itself thereby lessening the impact of protection on data rate. Of course, protection is possibly required at each node increasing the likelihood that either data rate or distance will be compromised by adding protection circuitry.

Optical Isolation

Optically isolated transceivers can be treated like DC coupled transceivers. **The termination and fail-safe bias issues are the same, so what is isolated?** What is isolated are signals TXD, RTS and RXD. Therefore, three opto-isolators are required. The two used for data should be high speed while the transceiver enable isolator can be slower. A DC-DC converter needs to be provided and its breakdown voltage will probably be the limiting factor in terms of isolation. The optically isolated transceiver design is the most expensive approach and it does not guarantee that the EIA-485 transceivers, which are connected directly to the cable, will survive abuse from severe electrical transients. Chances are, however, that the damage will stop at the isolators and not involve the equipment attached to the node. Optically-isolated EIA-485 forces a third wire connection since the transceivers must have a return path. However, this time there is no ground loop since logic ground of the transceivers is not connected to the earth. **Where do we get the third wire?** Many times the shield is used and not everyone is in agreement on the wisdom of this approach. Since such a small current is going to flow, it seems a reasonable approach. DH-485 uses a two pair cable with one wire of one pair dedicated as the common ground. A shield covers the two pairs and is only grounded at one point.

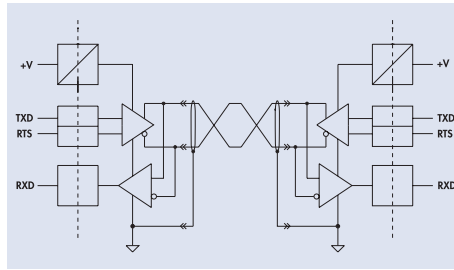

Sometimes the shield is used as the third wire with an optically-isolated interface.

CABLING

One of the more critical decisions to make is the selection of cable. There are many choices of cable and people incorrectly assume that any 24 AWG telephone cable will do. Cable selection depends on several factors including data rate, signal encoding and distance desired. Cables attenuate the transmitted signal and introduce distortion of the signal waveform itself. Additional distortion occurs by the way receivers are biased. Jitter can occur when the receiver attempts to recover the distorted data. Intersymbol interference results when a new signal arrives at the receiver before the last signal reached its final value. Therefore, the two successive symbols interfere with one another resulting in a time shift in the data recovery which is called jitter. National Semiconductor discusses this phenomenon in AN-808.⁹ Some jitter is usually acceptable, however, if it is excessive, the only solution is to obtain better cable, reduce the modulation rate or reduce the distance.

Other cabling issues include the wire size of the conductors, the need for shielding, the presence of a third wire ground and the type of insulation. It is best to only use the manufacturer's recommended cable and not substitute without consulting with the manufacturer first.

REPEATERS

EIA-485 segments can be extended using active hubs or repeaters; however, care needs to be exercised in the selection of repeaters. Since only two wires are used, the direction of signal flow through the repeater must change dynamically. Usually a direction control line is provided to the repeater to control flow or the repeater automatically senses traffic and adjusts accordingly. Do not assume any low-cost EIA-485 repeater will work at all speeds. Repeaters that sense line activity could be fooled in believing data flow from one direction has stopped when in fact it was a series of logic "1"s or "0"s without state transitions. This is especially true of RZ or NRZ encoded data. Repeaters that operate with a knowledge of the data link protocol are much more reliable than off-the-shelf solutions.

SUMMARY

With some attention to detail, EIA-485 can be an effective physical layer technology.

REFERENCES

1. Telecommunications Industry Association, *Electrical Characteristics of Generators and Receivers for Use in Balanced Digital Multipoint Systems, TIA/EIA-485-A*, March 1998.
2. Telecommunications Industry Association, *Application Guidelines for TIA/EIA-485-A, TSB89*, June 1998.
3. Rockwell Software, *SLC500 Modular Hardware Style Installation and Operation Manual, SLC500CD*, July 1998.
4. Profibus Trade Organization, *Profibus Standard-Part 1, DIN 19245*, 1993.
5. ASHRAE, *A Data Communications Protocol for Building Automation and Control Networks*, ANSI/ASHRAE 135-1995, Dec. 1995.
6. FieldComms USA, *ARCNET's Already Flexible Physical Layer Enhanced with Several EIA-485 Variants*, George Thomas, June 1997.
7. National Semiconductor, *A Comparison of Differential Termination Techniques*, AN-903, 1993.
8. National Semiconductor, *Fail-safe Biasing of Differential Buses*, AN-847, July 1992.
9. National Semiconductor, *Long Transmission Lines and Data Signal Quality*, AN-808, March 1992.