

Features & Benefits

- 4 x 0-10Vdc output channels
- Fused 24V output terminals for actuator power
- DIN Rail mounting
- Enables actuators or other equipment to be manually overridden
- Used as a fail-safe in event of controller failure

Technical Overview

The IO-ABM4 is used for independent manual override or buffering of analogue output channels from a BEMS controller, as a fail-safe in case of controller failure. This enables actuators and other plant to be manually overridden from the panel where local access may be difficult. The module is also useful for commissioning or temporary control of plant prior to controller installation.

Product Codes

IO-ABM4 4-Channel override module

Specification

Input signal	0-10Vdc
Output signal	0-10Vdc direct or buffered
Max. output current	20mA per channel in buffered mode
Power supply	21Vdc to 40Vdc 21Vac to 27Vac
Max. supply current	
AC supply	260mA
DC supply	115mA
Fused output	24Vac @ 8A
Manual override	Hand/Off/Auto Jumper selectable with screwdriver adjustment of output voltage in 'Hand' position 8A max.
Fuse	8A max.
Electrical connections	Rising cage terminals for 0.5-2.5mm ²
Ambient	-10 to 50°C
Dimensions	105 x 106 x 70mm
Country of origin	UK

WEEE Directive:



At the end of the products useful life please dispose as per the local regulations.
Do not dispose of with normal household waste.
Do not burn.



The products referred to in this data sheet meet the requirements of EU Directive 2014/30/EU

Installation



Antistatic precautions must be observed when handling these sensors. The PCB contains circuitry that can be damaged by static discharge.

1. The IO-ABM4 should only be installed by a competent, suitably trained technician, experienced in installation with hazardous voltages. (>50Vac & <1000Vac or >75Vdc & 1500Vdc)
2. Ensure that all power is disconnected before carrying out any work on the IO-ABM4.
3. Maximum cable is 2.5mm², care must be taken not to over tighten terminals.
4. When mounting the IO-ABM4 care should be taken not to stress the PCB when fitting to the DIN rail. If it is necessary remove the module from the DIN rail, be sure to use a flat bladed screwdriver to release the DIN clips.
5. The IO-AMB4 is designed to operate from a 24Vac/dc supply (so that power can be drawn from a 24Vac transformer used for other purposes if a 24Vdc supply is not available). In either case one side of the supply is common to the signal ground from the BEMS controller.

Note: if an input is left floating, and the output is buffered, if the output is set to FROM IPx then the output will be 15Vdc.

Connection & Jumper Settings

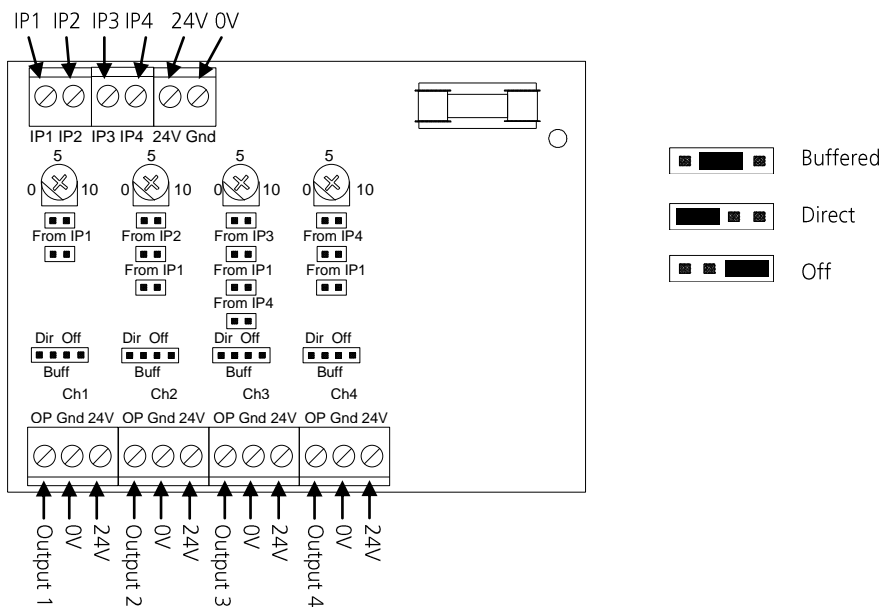

Output Linking

The jumper settings allow each output to be configured in a number of different ways as follows:-

- **Output 1:** Can be set to either HAND or IP1. Set to HAND, the output is adjusted using the corresponding potentiometer. Set to IP1, the output derives its value from input 1.
- **Output 2:** Can be set to HAND, IP1 or IP2. Set to HAND, the output is adjusted using the corresponding potentiometer. Set to IP1, the output derives its value from input 1. Set to IP2, the output derives its value from input 2.
- **Output 3:** Can be set to HAND, IP1, IP3 or IP4. Set to HAND, the output is adjusted using the corresponding potentiometer. Set to IP1, the output derives its value from input 1. Set to IP3, the output derives its value from input 3. Set to IP4, the output derives its value from input 4.
- **Output 4:** Can be set to HAND, IP1 or IP4. Set to HAND, the output is adjusted using the corresponding potentiometer. Set to IP1, the output derives its value from input 1. Set to IP4, the output derives its value from input 4.
- **Output buffer:** When an output link is set to the Buff position the output signal is buffered to 20mA, in both Hand and Auto modes.
- When an output link is set to the Dir position the output signal is powered only from the input in Auto mode or from the potentiometer in Hand mode.
- When an output link is set in the Off position, the output signal is open circuit.
- **Hand:** When the input link for a channel is set to Hand, the output voltage may be set by adjusting the associated potentiometer to give a fixed output.

Examples:

Each output set to be buffered and adjustable by on-board pot.

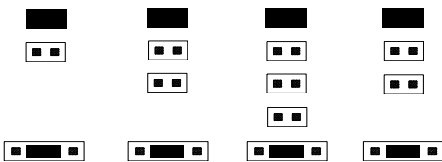

All 4 outputs are buffered and follow input 1.

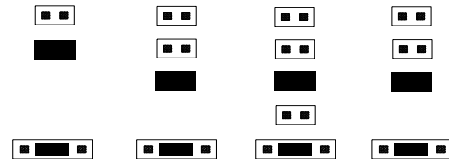

Outputs 1 & 2 are buffered and follow input 1, output 3 follows input 3 and is not buffered, output 4 is adjustable by the pot and is buffered.

