



MPC-10 Fully Programmable Thermostat

Description

by FjellCom

MPC-10 Bacnet programmable controller is a low cost high performance programmable controller. With an I/O configuration, it can be extended through external I/O modules to form a complete building automation solution.

There are five relays and two analog outputs as well as 8 universal inputs. These i/o can be configured using the free software. There are more than 300 settings with many options for each of the settings so its possible to configure these devices for most any application. Once the unit is configured, save the config file for copying to other controllers and backing up project settings. Options are available for occupancy sensor, zigbee, and humidity / enthalpy. Supports Bacnet MSTP and Modbus RTU for the RS485 model.

Wifi version supports Bacnet IP and Modbus IP



Highlights

- Universal I/O can be configured for nearly any sensor, no jumper settings required
- Well documented register list for easy integration with other systems.
- 8 universal inputs for external temperature sensors, contacts, etc.
- 5 relay outputs, each rated at 12~24vac, 2 amps
- 2 analog outputs, 0-10V @ 100ma.
- Color LCD display with scroll bar.
- Each I/O as well as the RS485 connections have a separate screw terminal
- Clock with infinite life supercap battery backup.
- Supports Modbus RTU and Bacnet protocols simultaneously.

Typical Application



Specifications

Outputs	5 relay outputs 2 analog outputs 10V@100mA
8 Universal Inputs	10k therm, contacts, 4-20ma, 0-5V, 0-10V
Operating range	-30~70°C(-22~158°F) / 0 to 99% RH
Supply voltage	12~24VAC/DC ±20%, 50-60Hz
Power consumption	100mA at 12VDC
Relay contacts	5 relays, 2A @ 24VAC UL File No.: E169380
Plastic Housing	Flammability rating UL 94 file E56070
Enclosure rating	IP31
Protocols	Bacnet MSTP and Modbus RTU
Baudrate	9600, 19200, 38400, 57600, 115200
Temperature sensor	10K thermistor ±0.5°C
Setup Software	Free, no licensing, open source

Size

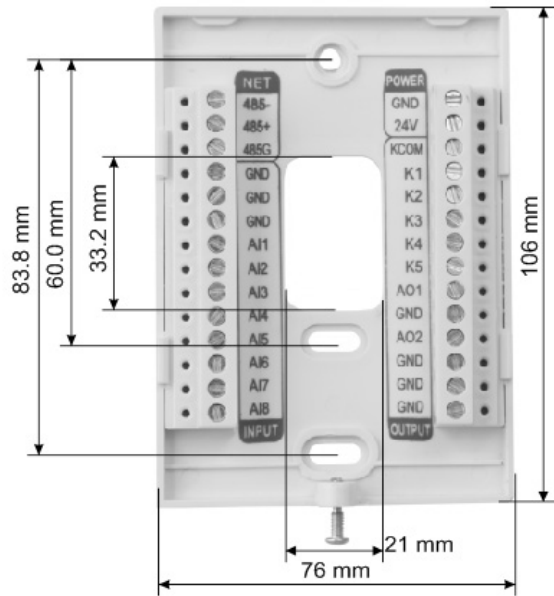

Wiring Diagram

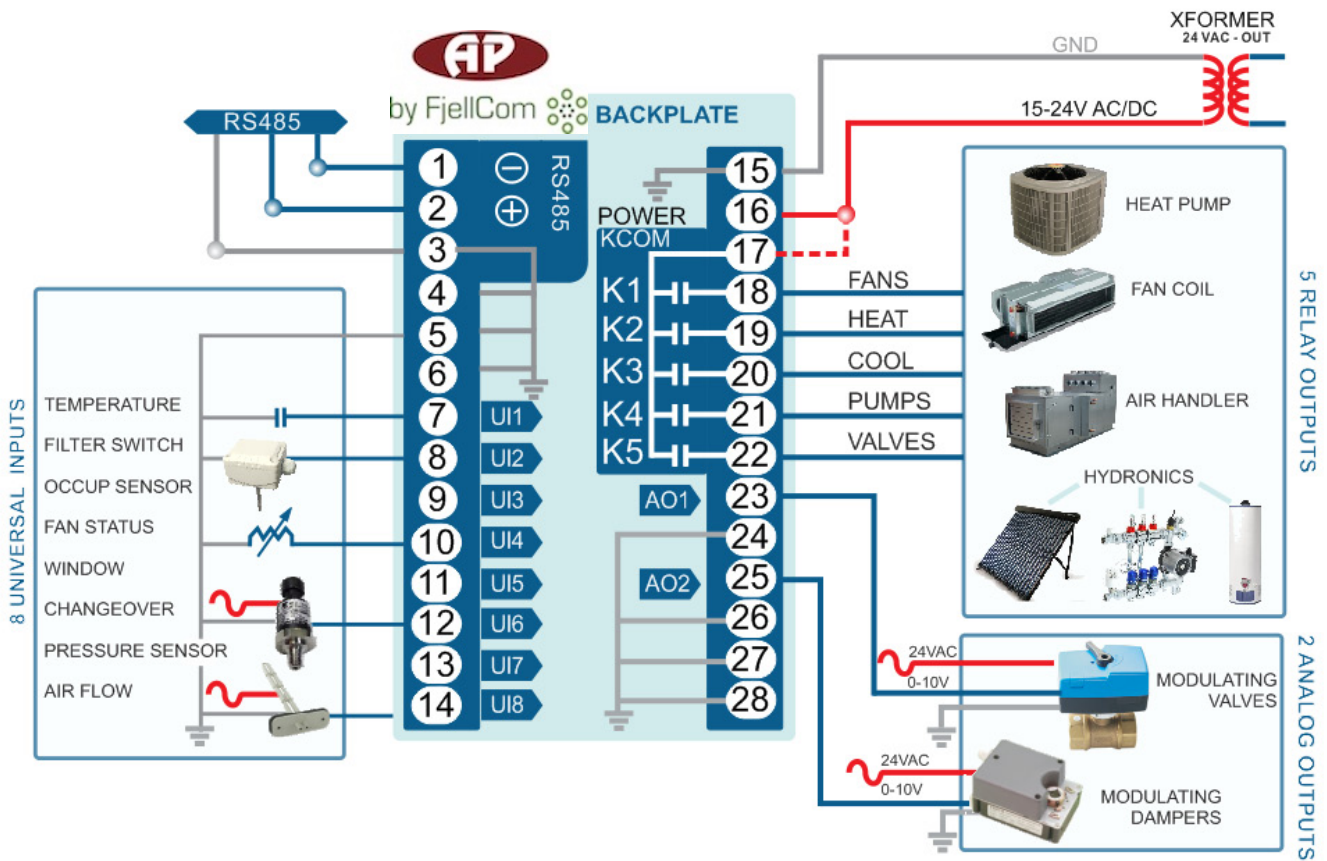

Approvals

Relay	UL File No.: E169380
Plastic Enclosure	PA66 UL 94 V0 file E56070
PCB	FR-4 Epoxy Glass Cloth UL E479892
Terminal Block	PA66 UL 94V-0

Software

8 analog inputs,2 analog outputs;5 digital outputs
Industry standard Bacnet & Modbus protocols
User screen displays
Day at home, work time, night at home, sleep, holiday

Bacnet Objects

Device	Object identifier;Object name;Object type;Vendor name;Vendor identifier; Model name;Firmware revision;Application software version; Protocol version;Protocol revision;Object list;Max apdu length accepted; Segmentation supported
Analog input	Object identifier;Object name;Description;Object type;Present value; Out of service;Units
Analog output	Object identifier;Object name;Description;Object type;Present value; Out of service;Units;Priority array
Analog value	Object identifier;Object name;Description;Object type;Present value; Out of service;Units;Priority array
Binary output	Object identifier;Object name;Description;Object type;Present value; Out of service;Units;Priority array;Polarity;Relinquish default;Active text; Inactive text

Highlights

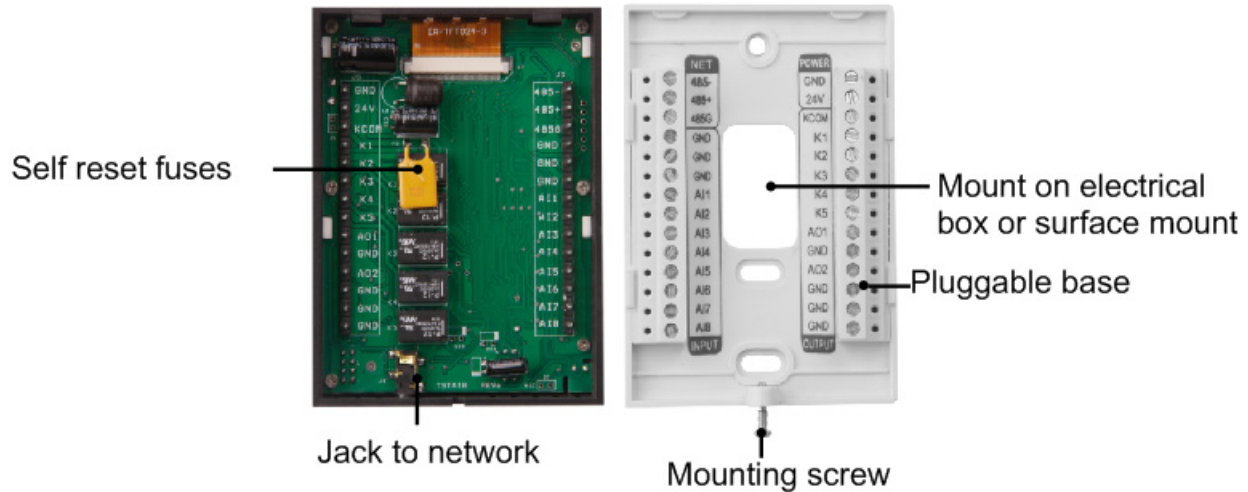

Advanced Menu Item Details

They have several advanced menu items which can be adjusted in the field to suit the application and tune the operation of the thermostat. Generally speaking, all the parameters are set up at the factory on an order-by-order basis and will give satisfactory results out of the box.

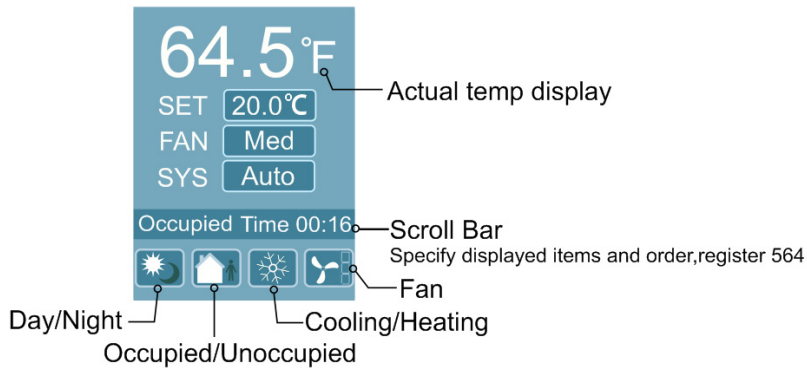

Register List

Address	R/W	Length	Description
0~3	R	4	Reserved for serial numblert
4~5	R	2	firmware Version Number
6	R/W	1	Modbus device address
7	R	1	Prodouct model
8	R	1	Hardware Version Number
9	R	1	PIC rev
12	R	1	UART0 Baudrate. 5 - 9600 , 6 - 19200
14	R	1	ISP Version
18	R/W	1	UART1 Baudrate. 5 - 9600 , 6 - 19200
19	R/W	1	UART2 Baudrate.(UART_1200 = 0, UART_2400 = 1, UART_3600 = 2, UART_4800 = 3, UART_7200 = 4, UART_9600 = 5, UART_19200 = 6, UART_38400 = 7, UART_57600 = 8, UART_115200 = 9, UART_921600 = 10
33	N	1	test cmd, write 77 - reboot, 100 - set default paramer, 111 - erase prg, 150 - clear tstat db
34	R	1	board type, big or small. 1 - big , 2 - samll,3-tiny,4-vav
35	R	1	instance number
36	R	1	station number
39	R/W	1	EN clear tstat db
42	R/W	1	USB MODE
43	R/W	1	EN DYNDNS ,// 0 - no 1 - disable 2 - enable
44	R/W	1	DYNDNS provider, // 0- www.3322.org 1-www.dyndns.com 2 - www.no-ip.com
45	R/W	1	dyndns update timer
46	R/W	1	NETWORK: MSB, MSB-1
47	R/W	1	MSTP NETWORK: MSB, MSB-1
51	R	1	TOP hardware
52	R	1	c8051f023 firmware rev
53	R	1	sm5964 firmware rev
...			

MPC-10-Wi i Set Up

Configuration Setting

To set the password and IP address of the MPC-10, two methods are available:Key setting and Adhoc setting or using the software Key setting.

First install this app in a android phoneAnd connect your phone with your wifi router,power on MPC-10.

The app will get the SSID from your phone and you need enter the wifi password, click confirm button then app will send a broadcast message through wifi router to MPC-10