



Rotary Damper Actuator Modulating 0(2)-10Vdc/0(4)-20mA RA32VC

Jan.10



Features

- 32Nm torque to regulate dampers up to approx. 8m²
- Manual Override by push-button
- Anti-rotation bracket provided for stability
- Adjustable Angle of Rotation, Mechanical Endstops
- Simple direct mounting by Universal Adapter
- Reversible rotation
- Up to 10 Actuators can be connected in parallel
- Power Savings at End Stops

CE

RA32

Technical Data

Power Supply	24Vac/dc +/-10% 50/60Hz 230Vac +/-10% 50/60Hz
Power Consumption	
Operating	2,5W(24V) 3,8W(230V)
At the end stops	0.3W(24V) 0,7W(230V)
Wiring size	4,5VA(24V) 7,5VA(230V)
Control Signal(Input)	0(2)-10Vdc eller 0(4)-20mA
Feed back Signal	0(2)-10Vdc
Torque	32Nm
Aux.switching rating	3(1,5)@230Vac
Protection Class	IP54 with cable glands
Angle Limiting	Max 95 degree
Direction of Rotation	Bidirectional (right/left switch)
Angle of Rotation	-5...+85° wit 5°steps
Rotation angle	0-90°
Shaft Dimension Dia	10-20mm round / 10-16mm square
Running Time	sec
Noise Level	< 45dB (A)
Usage Life	Min. 60.000 open-close operations
Position Indication	Mechanical
Ambient Temperature:	-20...+ 50°C
Ambient Humidity:	5...95%rH non-condensing
Weight	1,1 kg
Maintenance	Maintenance free
Connections	Screw terminals
Standards	The actuators meet CE requirements

Short Description

By using the mounting clamp the actuators can be direct couple mounted over the damper shaft

The compact size allows for easy installation where space is limited.

Manual control through buttons available in the housing.

Actuator itself has ability of over-loading protect.

It stops automatically without limit switch

A mechanical limit operator is placed inside

Output signal amount 0-100%

Damper Size

When calculating the torque required to operate dampers, it is essential to take into account all the data supplied by the damper manufacturer concerning cross sectional area, design, mounting and air flow conditions.

The recommended damper size are guide values

Usage

RA32 modulating damper actuator is a high quality damper actuator for applications in HVAC system.

For use with air damper, butterfly valve, characterized ball valve and globe valve with use of special adapter.

Ordering 0(2)-10Vdc/0(4)-20mA

RA32 24VC	Damper Actuator	32Nm	24Vac/dc
RA32 220VC	Damper Actuator	32Nm	230Vac

0(2)-10Vdc/0(4)-20mA aux.sw.

RA32 32VCS2	Damper Actuator	32Nm	24Vac/dc aux.sw
RA32 220VCS2	Damper Actuator	32Nm	230Vac aux.sw



Damper Actuator Modulating 0(2)-10Vdc/0(4)-20mA RA32VC

Jan.10

Technical Overview

The RA32 range of actuators require 24Vac/dc supply and can accept either an 0(2)-10Vdc or 0(4)-20mA control signal input.

They are available with 32Nm torque rating and can have auxiliary switch options fitted.

The direction of rotation can be reversed and the angle of mechanical travel can be limited by up to 30 degree from either end.

Installation

1. Ensure that all power is disconnected before carrying out any work on the RA32.
 2. Maximum cable is 2,5mm², care must be taken not to over tighten terminals.
 3. Attach the actuator to the damper spindle, finger tighten the nut on the V-clamp.
 4. Fix the anti-rotation strap to the back of the actuator (bend if required).
 5. Move the damper to the closed position
 6. Using the manual override push button, turn the clamp until the actuator is in correct position.
 7. Tighten the V-clamp.
 8. If the damper has no fixed stops of its own, the angle of rotation/ working range can be adjusted mechanically by re-positioning the adapter in 5° steps.
- The adapter can be released by simply pressing the clip at the base of the actuator (see page 3).
9. Undo the screw on the cover of the actuator and remove the cover.
 10. Fit the cable gland into the back of the actuator
 11. Terminate the cores at the terminal block leaving some slack inside the unit.
 12. Replace the lid after the electrical connections have been made.
 13. Ensure that the voltage is within the specified tolerances.

Control signal setting

Control signal Y1:	0(2)...10 Vdc
Input resistance:	Ri 100 kOhm
Control signal Y2:	0(4)...20 mA
Input resistance:	Ri 500 Ohm
Feedback signal U:	0(2)...10 Vdc
Load resistance:	> 50 kOhm

Microswitch d

0...10 Vdc
0...20 mA



2...10 Vdc
4...20 mA

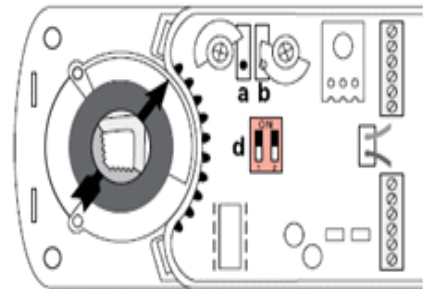

Direction of rotation setting

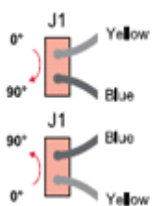

The direction of rotation can be changed by reversing Jumper J1.

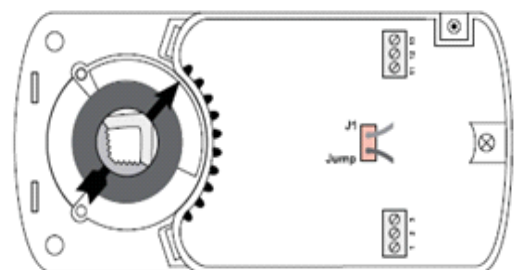



Rotary Damper Actuator Modulating 0(2)-10vdc/0(4)-20mA RA32VC

Jan.10

Auxiliary Switches

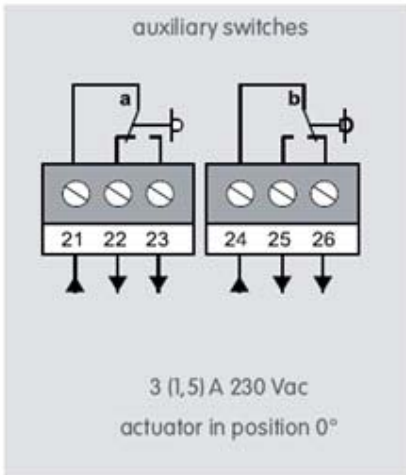

Auxiliary switches setting

Factory setting:
Switch a at 10°
Switch b at 80°
The switching position can be changed manually.

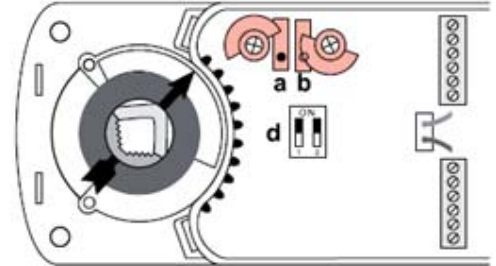

Electrical Connection 24Vac/dc

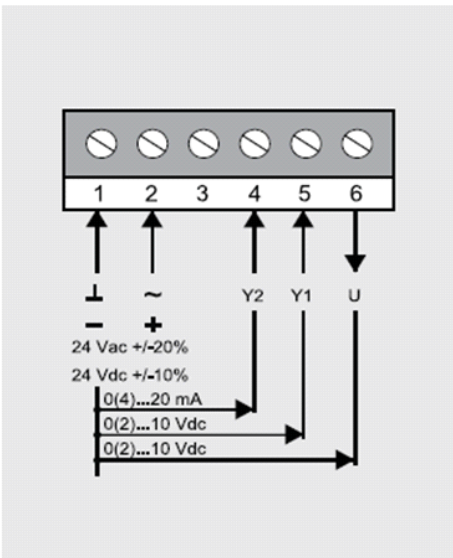

Electrical Connection 230Vac

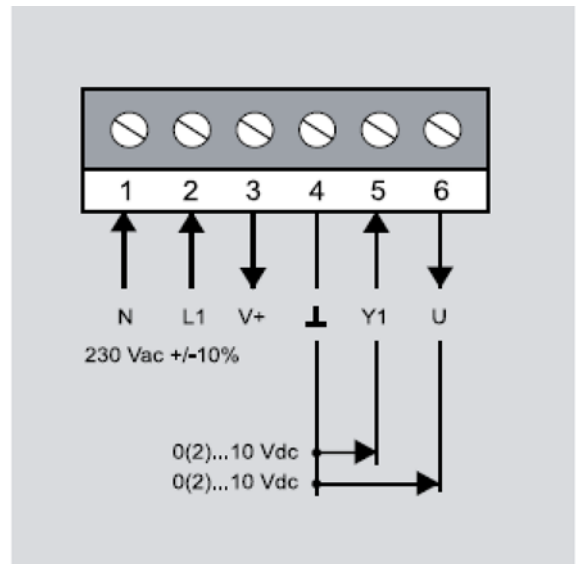

Parallel Connection of 24V

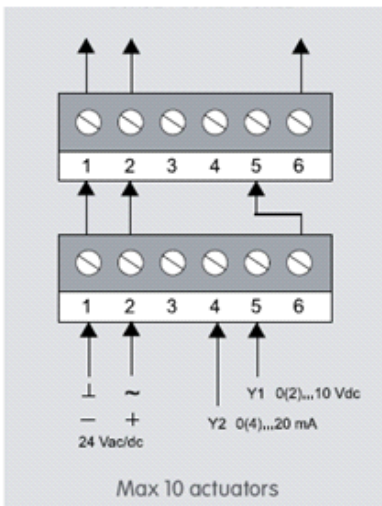

Limitation of rotation angle

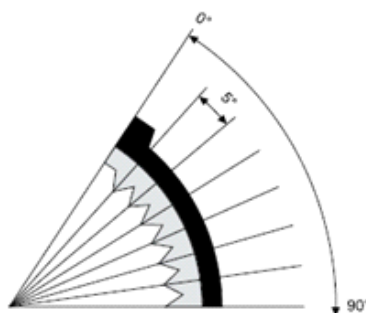

Adapter release

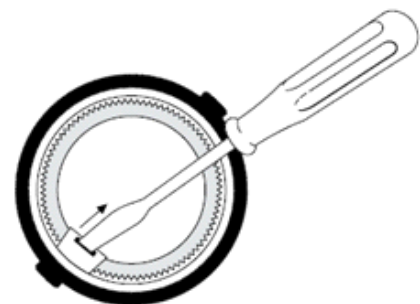



Damper Actuator Modulating 0(2)-10Vdc/0(4)-20mA

RA32VC

Jan.10

DIMENSIONS (mm)

